



MVE Variō™ Series with MVE Variō™ Pro Controller Technical Manual



Chart Inc.
2200 Airport Industrial Drive, Suite 500
Ball Ground, GA 30107





1.0 PREFACE

MVE Variō Pro

TECHNICAL MANUAL

PN 14930250 – Rev. A
January 2011



Chart Inc.

2200 Airport Industrial Drive, Suite 500
Ball Ground, GA 30107

Customer / Technical Service:

The Americas

Chart BioMedical

Phone: 770-721-7759 • Toll Free 1-800-482-2473

Fax: 770-721-7758 or 1-888-932-2473

Email: customerservice.usa@chartindustries.com
techservice.usa@chartindustries.com

Japan

Chart Japan Co., Ltd.

Phone: +(03) 5776 2670

Fax: +(03) 5776 2676

Email: customerservice.japan@chartindustries.com

Asia, Australia, & Pacific Rim

Chart Australia Pty Ltd.

Phone: +61 (2) 974 94333

Fax: +61 (2) 974 94666

Email: customerservice.australia@chartindustries.com

Europe

Chart BioMedical Ltd.

Phone: +44 (0) 1344 403100

Fax: +44 (0) 1189 799245

Email: customerservice.europe@chartindustries.com
technicalservice.europe@chartindustries.com

This manual covers the use and maintenance of MVE Variō Series Freezers and the associated MVE Variō Pro control system. It is intended for use by trained personnel only. **READ BEFORE USING THIS EQUIPMENT.** All service and maintenance should be performed by an authorized MVE Distributor.



NOTE: All MVE models are Class 1, externally powered, continuous operation medical devices. They are not suitable for use with flammable anesthetics. This equipment has been tested and found to comply with the limits for medical devices to IEC 601-1-2: [or EN 60601010102:2001 or Medical Device Directive 93/42/EEC].



2.0 TABLE OF CONTENTS

1.0 PREFACE 2

2.0 TABLE OF CONTENTS 3

3.0 SAFETY 5

4.0 CERTIFICATIONS & LISTINGS..... 7

5.0 PRODUCT INFORMATION 8

 5.1 MVE VARIÖ SERIES MODELS & SPECIFICATIONS 8

 5.1.1 Physical Dimensions 8

 5.1.2 Maximum Storage Capacity..... 9

 5.2 VARIÖ PRO CONTROLLER..... 10

 5.2.1 Display Panel Identification 10

 5.2.2 Connection Panel Identification 11

 5.2.3 Variō Pro Specs, Outputs, & Connections 12

 5.3 MVE VARIÖ OPERATING ENVIRONMENT 15

6.0 INSTALLATION & STARTUP..... 16

7.0 SYSTEM OPERATION 19

 7.1 Introduction 19

 7.2 The Hot Gas Bypass Cycle 20

 7.3 The Cooling Cycle..... 20

 7.3.1 Coil Outlet Temperature 20

 7.4 Cooling Cycle Termination 20

 7.5 Variō Pro Recommended Temperature Settings 21

 7.6 Variō Pro Default Settings 21

 7.7 Variō Pro System Alarms 22

 7.7.1 Alarm Definitions 22

 7.7.2 Remote Monitoring of System Alarms 24

 7.8 System Security 25

 7.9 Battery Backup..... 26

 7.10 Lid Switch 26

 7.11 Communications & Networking 27

 7.11.1 HyperTerminal 28

 7.11.2 ChartConnect 3000 32

 7.11.3 Printer Setup 33

8.0 SYSTEM SETUP & CUSTOMIZATION..... 34

 8.1 Temperature Settings 34

 8.1.1 Temp Sensors A & B 34

 8.1.2 Chamber Temperature / Coil Outlet Temperature & Deadband 35

 8.1.3 Inlet Temperature & Bypass Cycle 36

 8.1.4 Setting Liquid Nitrogen Temperature 37

 8.2 Battery Backup..... 38

 8.3 Lid Switch 39

 8.4 Controller Display & Output..... 40

 8.4.1 Temperature Units..... 40

 8.4.2 Alarm Buzzer 40

 8.4.3 Language Settings 41

 8.4.4 Printer Settings..... 41

 8.5 Security Setup 42



- 8.5.1 Password Entry Mode 42
- 8.5.2 Global Password 42
- 8.5.3 Multilevel Passwords 43
- 8.6 Advanced Settings 44
 - 8.6.1 Date & Time Adjustment..... 44
 - 8.6.2 Communications..... 45
 - 8.6.3 Unit ID / Modbus Menu..... 46
 - 8.6.4 Restoring Manufacturer Defaults 46
 - 8.6.5 Restarting the Controller..... 47
- 9.0 MVE VARIÖ PRO MENU MAPS 48
 - 9.1 Setup Menus..... 48
 - 9.2 Temperature Menus..... 48
 - 9.3 Temp A & B Menus 49
 - 9.4 Inlet Temp Menus 49
 - 9.5 Cooling Temp Menus 50
 - 9.6 Calibration Menus 51
 - 9.7 Add-on Menus 52
 - 9.8 Display & Output 52
 - 9.9 Advanced Settings 53
 - 9.10 Password Menus 54
 - 9.11 MVE Variō Pro Display Screens..... 55
 - 9.11.1 Power Up & Main Displays 55
 - 9.11.2 Alarm & Status Displays 55
- 10.0 PREVENTATIVE MAINTENANCE & TROUBLESHOOTING 56
 - 10.1 Preventative Maintenance Schedule 56
 - 10.2 Preventative Maintenance Procedures 57
 - 10.2.1 Calibrating the Pt1000 Temperature Sensors..... 57
 - 10.2.2 Testing the Remote Alarm Contacts..... 59
 - 10.2.3 Plumbing Leak Check..... 60
 - 10.2.4 Variō Pro Firmware Update 60
 - 10.2.5 Verifying Adequate LN2 Supply 60
 - 10.2.6 High Temperature Alarm Test 61
 - 10.2.7 Lid Thaw Procedure 62
 - 10.2.8 Folding Step Inspection 62
 - 10.2.9 Filter Replacement 62
 - 10.2.10 Relief Valve Replacement 62
 - 10.2.11 Complete MVE Variō Pro Function Test..... 62
 - 10.2.12 Solenoid Valve Replacement..... 63
 - 10.2.13 Lid Gasket Replacement 64
 - 10.2.14 Complete Freezer Thaw & Moisture Removal 64
 - 10.3 Accessories & Replacement Parts 65
- 11.0 EN COMPLIANCE TABLES..... 66
- 12.0 APPENDIX 69
 - 12.1 ASCII Interface & Command Index 69

3.0 SAFETY



READ BEFORE OPERATING THIS EQUIPMENT

3.1 INTRODUCTION

Liquid nitrogen (LN2) is used in MVE Cryogenic Freezers as a refrigerant. Understanding and following certain safety precautions is extremely important when handling LN2 and the associated cryogenic containers. Nitrogen is a colorless, odorless, tasteless gas. Gaseous nitrogen makes up about 78% of the Earth's atmosphere by volume. Once collected and isolated, nitrogen can be liquefied.

Properties of Nitrogen	
Boiling Point @ 1 atm	-195.8°C , -320.3°F , 77.4 K
Thermal Conductivity (Gas)	25.83 mW/(m·K)
Heat of Vaporization (Liquid)	198.38 kJ/kg
Density @ 1 atm (Liquid)	1.782 lbs/L , 807.4 g/L , 808.6 kg/m3

Operation of the MVE Variō Series Freezer and the associated MVE Variō Pro controller should be done in accordance with the manufacturer/supplier instructions. It is important that all safety precautions written herein and on the vessel itself be followed.

WARNING

- Nitrogen is a potential asphyxiant and can cause rapid suffocation without warning. Store and use in area with adequate ventilation. DO NOT vent container in confined spaces. DO NOT enter confined spaces where gas may be present unless area has been well ventilated. If inhaled, move to fresh air. If breathing is difficult, supplemental oxygen may be required. If not breathing, give artificial respiration. SEEK MEDICAL ATTENTION IMMEDIATELY.
- Liquid nitrogen can cause severe frostbite to the eyes or skin. DO NOT touch frosted pipes or valves. Cold nitrogen vapor can damage the eyes or skin. In case of frostbite, consult a physician immediately. If a physician is not readily available, warm the affected area with water that is near body temperature.
- NEVER place LN2 in a sealed container without a pressure relief device. The expansion ratio of liquid nitrogen to gaseous nitrogen is approximately 1 to 700 (i.e. 1 cubic foot of LN2 becomes 700 cubic feet of gas when evaporated).
- The two most important safety aspects to consider when handling LN2 are adequate ventilation and eye and skin protection. Although nitrogen gas is non-toxic, it will displace oxygen in a normal breathing atmosphere. Liquid products are of even greater threat since a small amount of liquid evaporates into a large amount of gas. Therefore, it is imperative that cryogenic supply and storage vessels be stored and operated in well ventilated areas.
- Persons transferring LN2 should make every effort to protect the eyes and skin from accidental contact with liquid or cold vapor. Chart MVE recommends the following protective clothing and accessories when transferring LN2 or handling hoses, valves, and plumbing components:
 - Cryogenic gloves (loose fitting)
 - Full-face shield or chemical splash goggles
 - Cryogenic apron
 - Long sleeve shirt and cuff-less pants
 - Closed toe shoes



3.2 RECOMMENDED FIRST AID

Every site that stores and uses LN₂ should have an appropriate Material Safety Data Sheet (MSDS) present. The MSDS may be obtained from the manufacturer/distributor and will specify the symptoms and treatment of over-exposure to liquid or gaseous nitrogen. A typical summary is shown below:

- If symptoms of asphyxia such as headache, drowsiness, dizziness, excitation, excess salivation, vomiting, or unconsciousness are observed, remove to fresh air. If breathing is difficult, supplemental oxygen maybe required. If breathing has stopped, CALL A PHYSICIAN IMMEDIATELY.
- If exposure to cryogenic liquids or cold vapor occurs, restore tissue to normal body temperature (98.6°F, 37°C) as quickly as possible and protect the injured tissue from further damage. Rapid warming of the affected area(s) is best achieved by bathing in warm water. The temperature of the water used should not exceed 140°F, 40°C. Under no circumstances should the affected area be rubbed or otherwise agitated in any way, either before or after warming. If the eyes are affected, flush them thoroughly with warm water for a minimum of 15 minutes. In the event of a massive exposure, remove clothing while showering with warm water. The affected individual should not drink alcohol or smoke. CALL A PHYSICIAN IMMEDIATELY.

3.3 EQUIPMENT USAGE

Cryogenic containers must be operated in accordance with the manufacturer/supplier instructions. Safety instructions will also be posted on the side of the vessel. Cryogenic containers must be kept in a well-ventilated area protected from weather and away from heat sources. In applications utilizing a modular liquid cylinder as a source of LN₂, the supply will need to be replenished at regular intervals to ensure proper operation of the freezer. When exchanging liquid cylinders, follow the below procedure:

1. Allow all plumbing components to warm to room temperature before attempting to change supplies.
2. Close all valves associated with the liquid supply cylinder.
3. Relieve pressure in the plumbing assembly by pressing the manual override button at the bottom of the Variō Pro controller.
4. Loosen the plumbing connection for the transfer hose at the liquid cylinder.
5. Remove empty liquid cylinder and replace with full liquid cylinder pressurized to 22 - 35 psig (1.52 - 2.41 bar).
6. Attach the transfer hose to the plumbing connection on the liquid cylinder. Ensure that the hose is connected to the connection labeled *LIQUID*.
7. Tighten the transfer hose connection at the liquid cylinder.
8. Open the liquid supply valve on the liquid cylinder.
9. Inspect plumbing for audible and visual leaks. Repair if necessary.
10. Manually initiate a cooling cycle to verify proper operation.



4.0 CERTIFICATIONS & LISTINGS

All fully automated Chart MVE cryogenic freezer systems equipped with MVE Variö Pro controllers are UL / C-UL listed and CE marked to the Low Voltage Directive (LVD). Specially designated freezer models are also CE marked to the Medical Device Directive (MDD). The LVD is a European Union directive regulating the construction and operation of electrical equipment that is not considered a medical device. The MDD is a European Union directive regulating medical device construction and operation. These listings and certifications are not limited to the electronic controller alone, but encompass the entire freezer system as a whole.



M.D.D. Representative:
Medical Product Services
Borngasse 20
35619 Braunfels, Germany

5.0 PRODUCT INFORMATION

5.1 MVE VARIŌ SERIES MODELS & SPECIFICATIONS

Chart MVE offers a wide range of fully automated LN2 freezers that can accommodate a variety of inventory systems designed to meet all of your cryogenic storage needs. Each MVE Variō Series freezer is a hand-made, double-walled, vacuum insulated stainless steel Dewar designed to maintain an internal temperature anywhere from -50°C to -150°C with minimal energy costs and environmental impact. The physical dimensions and storage capabilities for each model are as follows:



5.1.1 Physical Dimensions				
	MVE Variō 1536P	MVE Variō 1539R	MVE Variō 1879P	MVE Variō 1881R
Inner Diameter, in. (mm)	38.5 (978)	38.5 (978)	56.0 (1422)	54.8 (1391)
Lift-over Height, in. (mm)	37.1 (944)	37.1 (944)	40.2 (1021)	38.8 (985)
Max. Floor Loading Pressure, kPa (Caster base area)	15.50	15.50	25.22	29.67
Max. Point Pressure per Caster (kPa)	7760	7760	17465	18398
Minimum Ceiling Height, in. (mm)	83.2 (2115)	83.2 (2115)	90.3 (2294)	88.9 (2257)
Minimum Door Width, in. (mm)	42.0 (1067)	42.0 (1067)	60 (1524)	60 (1524)
Neck Opening, in. (mm)	17.5 (445)	17.5 (445)	25.0 (635)	25.0 (635)
Overall Height, in. (mm)	61.3 (1556)	63.3 (1607)	62.1 (1577)	61.3 (1556)
Usable Internal Height, in. (mm)	28.8 (732)	30.8 (782)	29.5 (749)	29.5 (749)
Weight Empty, lbs. (kg)	690 (313)	690 (313)	1606 (728)	1721 (781)

5.1.2 Maximum Storage Capacity

	MVE Variö 1536P	MVE Variö 1539R	MVE Variö 1879P	MVE Variö 1881R	
1.2 & 2.0 ml Vials (Internally Threaded):					
Total Capacity	36400	39200	79950	81900	
Number of 100 Cell Box Racks	24	24	54	60	
Number of 25 Cell Box Racks	16	16	30	12	
Number of Boxes Per Rack	13	14	13	13	
Blood Bags:					
791 OS/U (25ml)	Total Capacity	3080	3064	5866	5628
	Bags / Frame	7	8	7	7
	No. of Frames	440	383	838	804
Compact (25ml)	Total Capacity	4338	4338	8622	9414
	Bags / Frame	9	9	9	9
	No. of Frames	482	482	958	1046
4R9951 (50ml)	Total Capacity	1488	1736	2952	2940
	Bags / Frame	6	7	6	6
	No. of Frames	248	248	492	490
DF200 (200ml)	Total Capacity	496	812	1584	1608
	Bags / Frame	4	4	4	4
	No. of Frames	124	203	396	402
4R9953 (250ml)	Total Capacity	812	608	1104	1240
	Bags / Frame	4	4	4	4
	No. of Frames	203	152	276	310
4R9955 (500ml)	Total Capacity	608	496	960	984
	Bags / Frame	4	4	4	4
	No. of Frames	152	124	240	246
DF700 (700ml)	Total Capacity	256	256	504	544
	Bags / Frame	4	4	4	4
	No. of Frames	64	64	126	136

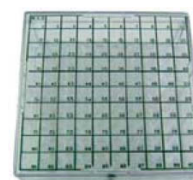
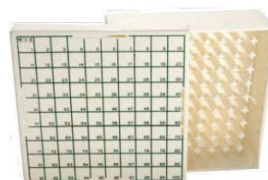

5.2 VARIÖ PRO CONTROLLER

5.2.1 Display Panel Identification



Display Panel Identification Key		
Front Panel	The front panel is the user interface for the Variō Pro. All displays and controls are located on the front panel.	
Display	A 4 x 20 Liquid Crystal Display (LCD) shows the value of all current conditions. The display also shows any current alarm conditions that may exist.	
		Used to manually clear the fog from the storage area to increase visibility.
		Used to manually end the fog clear process.
		Used to adjust the value of all user adjustable functions including Temperature Alarms, Passwords, Etc.
		Used to silence the audible alarm. Also used to reset the latching alarm after the alarm condition is corrected.
		Used to increase number values in setup menus. Press once to decrease incrementally. Hold the button down to scroll quickly. Also be used to toggle YES/NO or ENABLED/DISABLED values.
		Used to decrease number values in setup menus. Press once to decrease incrementally. Hold the button down to scroll quickly. Also be used to toggle YES/NO or ENABLED/DISABLED values.
		Short for <i>escape</i> , this button is used to exit any menu or setup function.
		Used to select any menu for editing or save any user setting.

5.2.2 Connection Panel Identification



Connection Panel Identification Key	
TEMP A	Platinum RTD connection for primary sensor
TEMP B	Platinum RTD connection for auxiliary sensor
30VDC INPUT	Connection for main power supply.
SERIAL I/O	RS-485 input/output connection
MANUAL FILL	Manual override button, forces cooling valves open
SENSOR/ALARM OUTPUT	Output connection for the remote monitoring of Temp A & various alarm conditions.
GLOBAL REMOTE	Output connection for the remote monitoring of all alarm conditions. Any Variō Pro system alarm will cause the NC, NO contacts to switch state. These connections may be wired to any remote monitoring system utilizing normally closed (NC) or normally open (NO) contacts.
MAIN WIRE HARNESS	Connection for main wire harness. All system components are wired through this connection, with the exception of Temp A, Temp B, and the main power supply.



5.2.3 Variō Pro Specs, Outputs, & Connections

Physical Dimensions	
Length	9.1 in. (232 mm)
Width	3.5 in. (89 mm)
Height	8.0 in. (203 mm)
Weight	6.5 lbs. (2.95 kg)

Display	
Type	Liquid Crystal Display (LCD) with backlight
Size	20 x 4 Character
Resolution	8 x 5 Pixels per Character
Keypad	8 keys, Multi function

Electrical Specs	
MVE Variō Pro	
Input Voltage	30 VDC
Input Current (max.)	5 A
Input Current (continuous)	1 A
Power Consumption (max.)	28 W
Power Consumption (continuous)	8 W
Solenoid Valve Output Voltage	24 VDC
Short Protection	Current limiting, automatic reset
Jerome Power Supply (WSL730M V1)	
Input Voltage	110-230 VAC, automatically switching
Input Frequency	50-60 Hz
Output Voltage	30 VDC
Current Capability (max.)	3 A
Input Current	0.73 A @ 110 VAC, 0.35 A @ 230 VAC
Power Requirements (Variō Pro + Power Supply)	
Continuous Input Current	< 0.1 A @ 110 VAC
Maximum Input Current	0.3 A @ 110 VAC
Continuous Input Power	8 W
Maximum Input Power	30 W

Physical Connections	
Temperature Probes	2-pin twist lock
Input Power	5-pin DIN
Main Wire Harness	15-pin AMP
Serial I/O Port	RJ-45, 4-pin RS-485
4-20mA & Alarm Output	DB15
Global Alarm Contacts	Clamp Connection

Temperature Sensors	
Type	2-wire Platinum RTD (Pt1000)
Quantity	4
Resistance	1000 Ω @ 0°C
Sensitivity	3.85 Ω / °C
Resolution	0.1°C (0.2°F)
Accuracy	Single Point Calibration: ± 1.0°C (1.8°F) Two Point Calibration: ± 2.0°C (3.6°F)
Range	- 200°C to 70°C (- 328°C to 158°F)

MVE Variö Pro Outputs	
Port / Connection	Output
Main Wire Harness PINS 10 ⁺ & 11 ⁻ (Bypass Valves)	+24VDC, 1.5A
Main Wire Harness PINS 4 ⁺ & 5 ⁻ (Cooling Valves)	+24VDC, 1.5A
DB15, PIN 1 (Analog Temperature)	4-20mA scaled from -200C to 20C
DB15, PIN 6 (High/Low Temp Alarm)	Discrete Contact, Isolated Open Collector – Max: 24VDC, 100mA
DB15, PIN 7 (Lid Open Alarm)	Discrete Contact, Isolated Open Collector – Max: 24VDC, 100mA
DB15, PIN 13 (Valve Stuck Open/Closed Alarm)	Discrete Contact, Isolated Open Collector – Max: 24VDC, 100mA
Global Remote (Normally Closed)	230VAC, 1A max
Global Remote (Normally Open)	230VAC, 1A max

Main Wire Harness		
PIN	Description	Function (I/O)
1	Battery Backup 24VDC +	Input/Output
2	Battery Backup 24VDC -	Input/Output
3	Lid Switch 1	Input
4	Cooling Valves 24VDC +	Output
5	Cooling Valves 24VDC -	Output
6	Lid Switch 2	Input
7	Cooling Temp Sensor +	Input
8	Cooling Temp Sensor -	Input
9	Inlet Temp Sensor +	Input
10	Bypass 24VDC +	Output
11	Bypass 24VDC -	Output
12	Inlet Temp Sensor -	Input

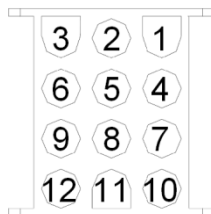

DB15 Connection		
PIN	Description	Function (I/O)
1	Analog Temp +	Output
2	¹ Analog +	Output
3	Not Used	-
4	Not Used	-
5	Not Used	-
6	High/Low Temperature Alarms (NO)	Output
7	Lid Open Alarm (NO)	Output
8	Sensor Failure Alarm (NO)	Output
9	Analog Temp -	Output
10	¹ Analog -	Output
11	Not Used	-
12	Not Used	-
13	Stuck Valve Alarm (NO)	Output
14	+5VDC (Supplied)	-
15	Common	-

¹Circuit is connected, but unassigned.

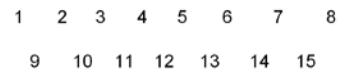

Serial I/O Port		
PIN	Description	Function (I/O)
1	TXA (Transmit +)	Output
2	TXB (Transmit -)	Output
3	Ground	-
4	Ground	-
5	RXA (Receive +)	Input
6	RXB (Receive -)	Input
7	No Connection	-
8	Ground	-

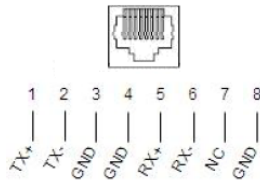

Global Remote Alarm ¹		
PIN	Description	Function (I/O)
1	Normally Closed	Output
2	COM	Output
3	Normally Open	Output

¹All Global Alarm connections are non-polarity sensitive, latching, dry contact relays with an output of 230VAC at 1A.

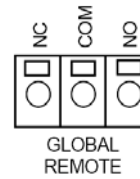

Chamber Temp Sensors		
PIN	Description	Function (I/O)
1	Chamber Temp A +	Input
2	Chamber Temp A -	Input
1	Chamber Temp B +	Input
2	Chamber Temp B -	Input

Main Power Supply (30 VDC)		
PIN	Description	Function (I/O)
1	Ground	-
2	Chassis Ground	-
3	28VDC	Input
4	NC	-
5	NC	-



5.3 MVE VARIŌ OPERATING ENVIRONMENT

5.3.1 Ambient Temperature & Relative Humidity

MVE cryogenic freezers are designed to be operated in environments near room temperature (65°F – 80°F, 18°C – 27°C) and with a relative humidity below 50%. However, a small variance of a few degrees outside of this range will not have a significant impact on the performance of the freezer. The relative humidity should be maintained low enough to keep condensation build up to a minimum, as elevated humidity levels can lead to excessive condensation and frost on and around the lid. In situations where the relative humidity is high and uncontrollable, the lid should be routinely wiped dry to prevent the formation of ice. Should significant ice formation develop, refer to the Preventative Maintenance procedures included with this document for thawing instructions.

5.3.2 Thermal Load

MVE Variō Series freezers use LN₂ as the refrigerant and do not employ any type of mechanical refrigeration. Therefore, the thermal load will be negligible to negative.



6.0 INSTALLATION & STARTUP

This section will review the basic receiving, installation, and startup procedures for MVE Variō Series freezers. Always inspect the bill of lading for accuracy and external crate/packaging for damage before accepting the shipment.

Included with each MVE Variō Series unit:

- Literature Packet
 - MVE Variō Pro Quick Start Reference Guide – PN 14910831
 - Manual Freezer Status Log – PN 10936355
 - Warranty Statement / Registration / Certificate
- MVE Variō Pro Controller (Packaged in a separate box) – PN 14911278
- 6' Transfer hose (Inside freezer) – PN 9713109
- Desiccant bag (Inside freezer. To be removed and discarded.)
- Liquid Nitrogen handling instructions
- MVE Checklist (Signed by shipping inspector)



Note: To avoid injury or damaging the equipment, do not apply power to the MVE Variō Pro controller, connect a battery backup, or connect an LN2 supply to the freezer until setup is complete.

Installation Procedure:

Following the careful uncrating and unpacking of the freezer, install using these basic instructions:

1. Ensure all of the plumbing assembly connections to the MVE Variō Pro wire harness are secure.
2. Connect the 12-pin wire harness to the MVE Variō Pro wire harness connection.



3. If the freezer is equipped with battery backup, the included battery fuse must be installed before connecting the battery to the main wire harness. Open the battery enclosure and unscrew the fuse harness. Install the fuse and close the fuse harness and the battery enclosure.



NOTE: Do not connect the battery backup to the main wire harness until setup is complete.

4. Connect Temp A & B temperature sensors to the corresponding twist-lock connection.



5. Plug in the power supply to an appropriate wall outlet with the proper AC voltage. Avoid wall outlets that are connected to emergency generator power if possible. Although an uninterruptible power supply (UPS) is ideal, a surge protector or power conditioner is recommended.
6. If applicable, connect the battery backup to the main wiring harness. While running on outlet power, the MVE Variō Pro supplies a steady 27 VDC trickle charge to the battery backup. The battery backup may need to be charged for several hours before it is able to power the MVE Variō Pro.



7. It is recommended that empty inventory system components such as racks, boxes, frames, or canisters be introduced prior to initiating the first cooling cycle. This will allow the racks, frames, etc. to cool with the freezer.
8. Remove the cap-plug from the fill tee on the plumbing assembly and connect the LN2 supply. If a modular LN2 cylinder is being utilized as the liquid supply, securely connect and tighten the transfer hose to both the fill tee connection and the supply connection labeled *LIQUID*. If a bulk LN2 supply system is employed, securely connect and tighten the supply connection to the freezer fill tee connection.



NOTE: The recommended LN2 supply pressure is 22-35 psig (1.52 - 2.41 bar).

9. Plug the power supply into the MVE Variō Pro 30 VDC power input. The MVE Variō Pro display should illuminate and begin the startup sequence.



10. Following the startup sequence, the MVE Variō Pro will start to alarm and initiate a cooling cycle. This is normal.
11. Press *ALARM MUTE* to silence the audible buzzer for 30 minutes. For installation and startup purposes, the alarm buzzer can be disabled; however, it is recommended that it be re-enabled when installation is complete.
12. Ensure that freezer lid is closed and open the LN2 supply valve.
13. The initial cool-down cycle will take significantly longer than subsequent cooling cycles, and excessive condensation / ice buildup on the lid and plumbing can be expected. However, it is important that the lid not be removed during this period.
14. When the freezer reaches the chamber temperature set point minus the chamber deadband, the Variō Pro will terminate the cooling cycle. The frost and ice buildup will melt and evaporate soon thereafter, and normal operation will commence.

7.0 SYSTEM OPERATION

Efficient offset neck and hinged lid design maximizes vacuum insulated surface area to maintain consistent temperature profile, even with the lid open.

Rotating interior tray allows easy access to freezer samples

Two-tier folding step provides lowest liftover height

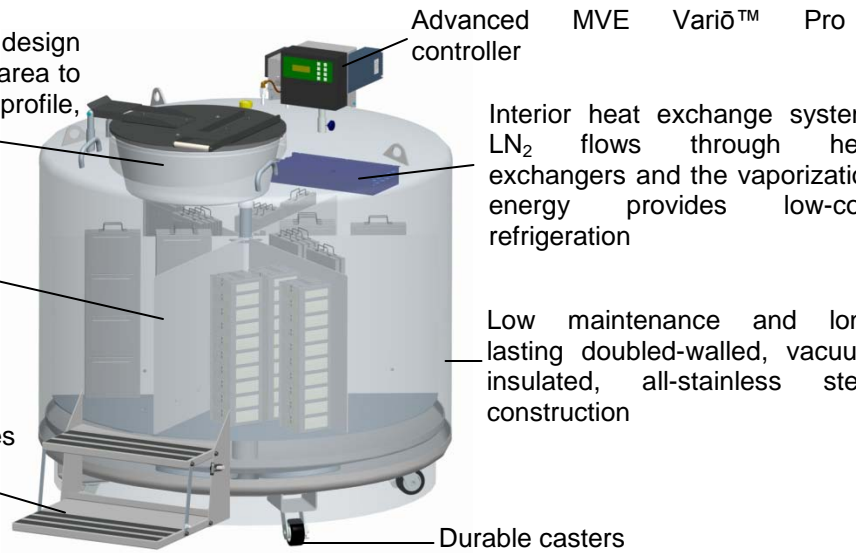

7.1 Introduction

MVE Variō™ Series freezers operate using an innovative, patent-pending refrigeration system utilizing liquid nitrogen (LN₂) as the sole refrigerant. When a cooling cycle is initiated, LN₂ flows from the supply source and through a heat exchanger located beneath the top head of the freezer, making use of the principle of *evaporative cooling* to maintain ultra-low to cryogenic storage temperatures.

This heat transfer system was developed by MVE to fully utilize the heat capacity of LN₂ while simultaneously purging frost and moisture from the storage space. The MVE Variō Pro controller monitors and meters the amount of LN₂ flowing through the heat exchanger to maintain the completely dry storage space within $\pm 5^{\circ}\text{C}$ of the user-defined storage temperature, which can be set anywhere from -50°C to -150°C . The efficient offset neck design and double-walled, vacuum insulated, all-stainless steel construction provides a consistent temperature profile throughout the storage space – even with the lid open. While the lid is open, the MVE Variō™ automatically compensates by shortening the cooling cycle interval so that the storage space temperature does not increase above of the desired range. A schematic of the Variō Pro plumbing is shown below, and may be used as reference for the sections that follow.

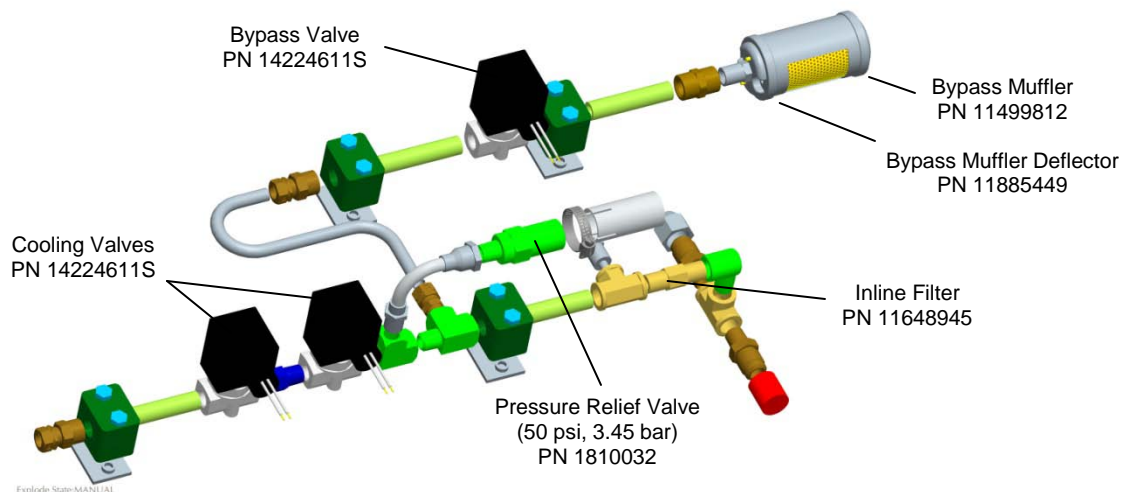



7.2 The Hot Gas Bypass Cycle

The *Hot Gas Bypass Cycle*, or simply the *Bypass Cycle*, is the first process initiated when controller begins cooling the MVE Variō freezer, and is intended to purge, or bypass, all of the warm nitrogen gas sitting stagnate in the supply line to the freezer. The controller will open the bypass valve and allow the warm nitrogen gas to continue purging until the *inlet temperature sensor* reaches its user-defined setpoint, at which point the bypass valve will close, the cooling valves will open, and the *Cooling Cycle* will begin. The inlet temperature setpoint may be adjusted by the user in the Variō Pro *Inlet Temp Menu*:

Inlet Temp Setpoint
-70.0°C
Use ▼▲ to adjust
Press ENTER to save

7.3 The Cooling Cycle

The *Cooling Cycle* is the process by which the MVE Variō system maintains an internal temperature within the range specified by the user. When the storage chamber warms above the *maximum chamber temperature*, the Variō Pro will begin purging the warm nitrogen from the supply line and initiate a cooling cycle immediately thereafter. Note that this function is automatic and cannot be manually overridden by any process short of physically disconnecting the unit. As the cooling cycle continues, LN2 flows through the heat exchanger, sometimes referred to as the *cooling coil*, and evaporates into gaseous nitrogen. At that point, the nitrogen exits the cooling coil and passes by the *coil temperature sensor*, also called the *cooling sensor*, on its way. The maximum chamber temperature may be adjusted by the user in the Variō Pro *Cooling Menu*:

Max Chamber Temp
-80.0°C
Use ▼▲ to adjust
Press ENTER to save

7.3.1 Coil Outlet Temperature

The *coil outlet temperature*, also called the *cooling temperature*, is the temperature of the gaseous nitrogen as it exits the heat exchanger, and is measured by cooling sensor. What the cooling sensor does is ensure that the temperature of the nitrogen exiting the heat exchanger is not so cold that it causes the temperature of the storage area to fall below the user-defined range when it is purged through the chamber. If it is, the cooling valves will close and allowing the nitrogen to warm to the temperature defined by the minimum coil outlet temperature plus the *coil outlet deadband*, at which point the cooling valves will open and the cooling cycle continue. Both the minimum coil outlet temperature and the coil outlet deadband may be set by the user in the Variō Pro *Cooling Menu*:

Min Coil outlet temp
-60.0°C
Use ▼▲ to adjust
Press ENTER to save

Coil outlet deadband
10.0°C
Use ▼▲ to adjust
Press ENTER to save

7.4 Cooling Cycle Termination

The MVE Variō system will continue cooling the storage chamber until it reaches the minimum chamber temperature, which is defined by the maximum chamber temperature minus the *chamber temperature deadband*, at which point the cooling valves will close and the cooling cycle terminate. The chamber temperature deadband may be adjusted by the user in the Variō Pro *Cooling Menu*:

Chamber Deadband
10.0°C
Use ▼▲ to adjust
Press ENTER to save



7.5 Variō Pro Recommended Temperature Settings

	Chamber Temperature -80°C to -90°C	Chamber Temperature -140°C to -150°C
Max Chamber Temp	-80°C	-140°C
Chamber Deadband	10°C	10°C
Min Coil Outlet Temp	-75°C	-135°C
Coil Outlet Deadband	20°C	20°C

High Temperature Setpoint	Max Chamber Temp
Low Temperature Setpoint	Max Chamber Temp - Chamber Deadband
Min Coil Outlet Temp	Max Chamber Temp + 5°C
Coil Outlet Deadband	20°C

7.6 Variō Pro Default Settings

Max Chamber Temp	-80°C
Chamber Deadband	10°C
Min Coil Outlet Temp	-75°C
Coil Outlet Deadband	20°C
Inlet Temp Setting (Gas Bypass)	-70°C
Gas Bypass / Supply Alarm Time Delay	5 minutes
Max Cooling Cycle Alarm Time Delay	120 minutes
High Temp Alarm	-75°C
Low Temp Alarm	-95°C
Temperature Display Units	°C
Stuck Valve Open Alarm Delay	30 minutes
Stuck Valve Closed Alarm Delay	30 minutes
COM 1 Type	ASCII
Event Log Interval	240 minutes
Global Password	3 4 5 6



7.7 Variō Pro System Alarms

The MVE Variō Pro controller is equipped with a total of 15 system status alarms, all of which may be customized by the user to suit the needs of the application. The various alarm indication screens and the corresponding descriptions are shown below.

7.7.1 Alarm Definitions

Alarm Display	Description
ALARM High Temp A Started at: 01/01/2011 12:00 PM	The Temp A sensor is reading above the user defined high temperature alarm setting.
ALARM High Temp B Started at: 01/01/2011 12:00 PM	The Temp B sensor is reading above the user defined high temperature alarm setting.
ALARM Low Temp A Started at: 01/01/2011 12:00 PM	The Temp A sensor is reading below the user defined low temperature alarm setting.
ALARM Low Temp B Started at: 01/01/2011 12:00 PM	The Temp B sensor is reading below the user defined low temperature alarm setting.
ALARM Temp A Sensor Fail Started at: 01/01/2011 12:00 PM	The Variō Pro has lost communication with the Temp A sensor. The sensor has either been disconnected from the controller or has been damaged.
ALARM Temp B Sensor Fail Started at: 01/01/2011 12:00 PM	The Variō Pro has lost communication with the Temp B sensor. The sensor has either been disconnected from the controller or has been damaged.
ALARM Inlet Sensor Fail Started at: 01/01/2011 12:00 PM	The Variō Pro has lost communication with the inlet sensor. The sensor has either been disconnected from the controller or has been damaged.
ALARM Cooling Sensor Fail Started at: 01/01/2011 12:00 PM	The Variō Pro has lost communication with the cooling sensor. The sensor has either been disconnected from the controller or has been damaged.
ALARM Supply Time X min Started at: 01/01/2011 12:00 PM	The Supply Time alarm is triggered when the temperature of the incoming nitrogen fails to reach the Inlet Temp Setpoint within the time specified by the Supply Alarm Delay. Once activated, the Variō Pro will terminate the Hot Gas Bypass cycle and begin supplying the freezer with N ₂ .
ALARM Valve Stuck Open Started at: 01/01/2011 12:00 PM	The Valve Stuck Open alarm is triggered when the Cooling Cycle has terminated and the Inlet Temp Sensor fails to warm above the Inlet Temp Setpoint within the time specified by the Stuck Open Delay time.



Alarm Display	Description
<p>ALARM Valve Stuck Closed Started at: 01/01/2011 12:00 PM</p>	<p>The Valve Stuck Closed alarm is triggered when the Variō Pro has begun feeding N₂ to the freezer, and the Inlet Temp Sensor fails to cool to the Inlet Temp Setpoint in the time specified by the Stuck Closed Delay time. Note that although this alarm is similar to the Supply Time Alarm, it will remain active regardless of the <i>ENABLED/DISABLED</i> status of the Inlet Temp Sensor.</p>
<p>ALARM Lid Open X min Started at: 01/01/2011 12:00 PM</p>	<p>This alarm is triggered when the <i>Lid Switch Installed</i> setting is set to <i>YES</i> and the freezer lid remains open for the duration of the time specified by the Lid Open Alarm Delay. Note that by default, the <i>Lid Switch Installed</i> setting is set to <i>NO</i>.</p>
<p>ALARM Cooling Time X min Started at: 01/01/2011 12:00 PM</p>	<p>The Cooling Time Alarm is triggered when the Variō Pro has initiated a Cooling Cycle and the Chamber Temp fails to reach the Chamber Temp Setpoint in the amount of time specified by the Cooling Time Alarm Delay.</p>
<p>ALARM Power Failure Started at: 01/01/2011 12:00 PM</p>	<p>The Power Failure Alarm is triggered when the Variō Pro is equipped with battery backup and has been running on battery power for 30 minutes. With typical use, a battery backup equipped Variō Pro will retain functionality for 72 hours after the loss of its primary power source.</p>
<p>ALARM Low Battery Started at: 01/01/2011 12:00 PM</p>	<p>The Low Battery Alarm is triggered when the voltage of the battery backup powering the Variō Pro drops below 21VDC.</p>
<p>Communications Loss Unit 1 Started/Ended at: 01/1/11 12:00</p>	<p>The Communications Loss screen is displayed in the event that the Display Screen has been disconnected from the Variō Pro control board. This screen does not necessarily indicate a loss of system functionality, but it does impair the user's ability to monitor the system status.</p>

7.7.2 Remote Monitoring of System Alarms

The Variō Pro is equipped with a DB15 connection port that provides, along with real-time temperature monitoring, 4 different normally closed alarm contacts for both high and low Temp A alarms, the Lid Open Alarm, Sensor Failure alarms for all four temperature sensors, and the Stuck Valve Alarms. As a catch-all, the Variō Pro also provides both a normally open and a normally closed latching alarm circuit monitoring the entire MVE Variō system. Any alarm condition will cause these *Global Alarm* contacts to switch state.

Once activated, these latching contacts will retain their alarm state until the alarm condition is corrected and cleared. For proper discrete contact function, ensure the negative (low voltage) terminal of the remote monitoring system is connected to the COMMON discrete contact terminal and the positive (high voltage) terminal is connected to the respective discrete alarm terminal. Wires can be inserted and removed from the terminals by placing a small flathead screwdriver into the slot above the contact and prying down the latch until the clamp connector opens. Remove the flathead screwdriver to close the clamp connector. Below are the remote alarm contact specifications and a typical remote monitoring setup schematic.

DB15 Connection		
PIN	Description	Function (I/O)
1	Analog Temp +	Output
2	¹ Analog +	Output
3	Not Used	-
4	Not Used	-
5	Not Used	-
6	High/Low Temp A Alarms (NC)	Output
7	Lid Open Alarm	Output
8	Sensor Failure Alarms	Output
9	Analog Temp -	Output
10	¹ Analog -	Output
11	Not Used	-
12	Not Used	-
13	Valve Stuck Open/Closed Alarm (NC)	Output
14	+5VDC (Supplied)	-
15	Common	-

¹Circuit is connected, but unassigned.

Global Remote Alarm ¹		
PIN	Description	Function (I/O)
1	Normally Closed	Output
2	COM	Output
3	Normally Open	Output

¹All Global Alarm connections are non-polarity sensitive, latching, dry contact relays with a max. output of 230VAC at 1A.

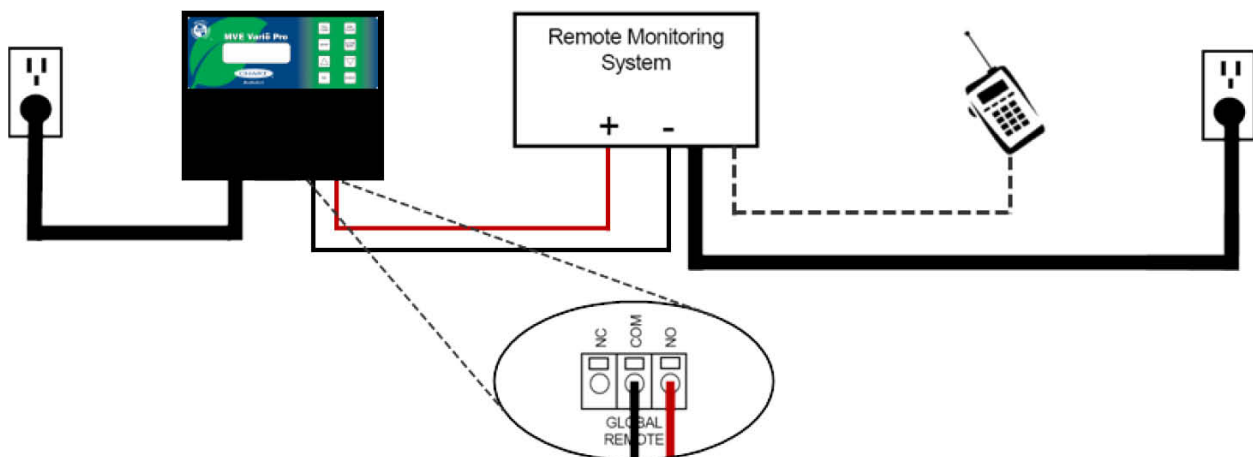
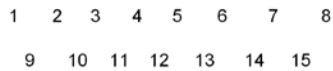
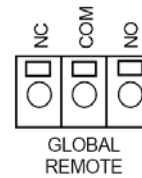



7.8 System Security

The Variō Pro has a multilevel security system that can be customized to meet your security needs. Four different levels of security can be assigned for up to 10 passwords. This allows system managers to control who has the ability to change specific settings and to what extent these settings may be altered. The access abilities of each security level are shown below. For instructions on how to create and manage a customized security system, see section 8.5 *Security Setup* on page 42.

Security Access Levels			
LEVEL 1	LEVEL 2	LEVEL 3	LEVEL 4
<ul style="list-style-type: none">▪ Fog Clear▪ End Clear▪ Alarm Mute▪ Change Display Units	Level 1 + : <ul style="list-style-type: none">▪ Temp Settings▪ Time & Date Settings▪ Calibration Menus▪ Language Selection▪ Hot Gas Bypass Menus	Level 2 + : <ul style="list-style-type: none">▪ Communications Settings▪ Programming	Level 3 + : <ul style="list-style-type: none">▪ Password Settings



Forgot your password? Contact your authorized MVE Distributor or the Chart-MVE Technical Service group.



7.9 Battery Backup

The Battery Backup is an optional feature on all MVE Variō Series freezers. In the event that the primary power source is compromised, the Variō Pro is able to maintain full functionality for approximately 48 hours while running on power from this external battery system. The MVE Variō Battery Backup is a fully automated, plug-and-play system with seamless power transfer.

Once the primary power source has been reconnected, the Variō Pro will automatically provide a continuous 27V trickle-charge until the battery power has been fully restored. In the event battery voltage falls below 21V, a Low Battery Alarm will activate, and at 18V, the Variō Pro will begin selectively disabling all non-critical systems to conserve power.

The Variō Pro power status may be viewed at any time in the *Add-On Menus*. During typical, externally powered operation, the screen will read *On AC Power*. When running off of auxiliary power, the screen will show the current battery power in volts as well as the percent battery power remaining.

Power Status On AC Power

Power Status 27V 100%

NOTE: The amount of time that an MVE Variō System will operate on backup power will vary depending on the temperature status, the typical interval of cooling cycles, and the size of the system being used.

7.10 Lid Switch

Although the MVE Variō system will maintain temperature regardless of the open/closed status of the lid, the Variō Pro controller has the built-in ability to support a lid switch monitoring circuit. This feature allows the user to take advantage of the *automatic fog clear* feature, and to activate the *Lid Open Alarm* if desired. Contact your MVE Authorized Distributor or the Chart Biomedical Customer/Technical Services team for further information.

7.11 Communications & Networking

The Variō Pro RS-485 serial interface offers several advanced communication capabilities including connecting to another MVE controller, a laptop/PC, a printer, or any other RS-485 enabled device. Up to 100 Variō Pro controllers may be integrated into a single network. A summary of the various communication / networking capabilities is shown below.



Warning: The Variō Pro should NEVER be connected directly to a LAN or public telecommunications network.



- **Laptop/PC**

The Variō Pro can communicate with any laptop/PC computer running either ChartConnect or Windows® HyperTerminal via an RS-485 to USB converter. Using the ASCII commands shown in section 12.1 *ASCII Interface & Command Index* on page 69, all Variō Pro settings and functions may be monitored and adjusted. A host computer may be connected to either a single controller, or a network of up to 100 controllers. A typical network schematic is shown below.

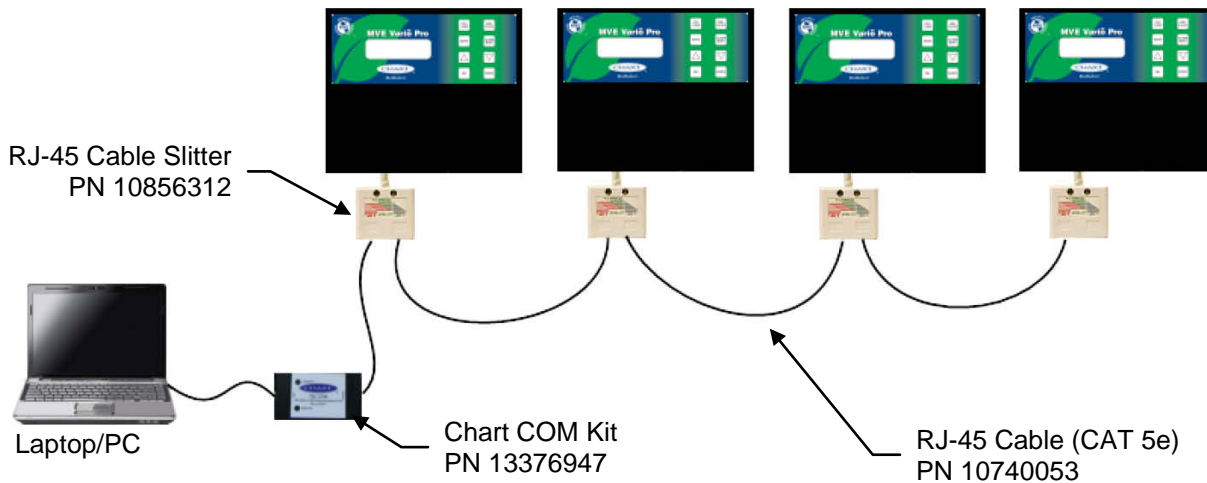

- **Printer**

The Variō Pro may be connected directly to a serial printer, allowing the user to print a hard copy of the freezer event log at a given interval and as events occur. The default print interval is 30 minutes. This gives users the opportunity to keep a hard-copy record of the freezer status in addition to the standard event log saved in the controller memory. This printed data bypasses the controller memory, providing an electronically inalterable record.

- **MODBUS®**

The Variō Pro is a MODBUS® RTU enabled device. For a register address map, contact your authorized MVE Distributor or Chart Technical Service.

COM Port Setup Options					
COM Type	COM Setup	Baud Rate	Data bits	Parity	Stop bits
ASCII	9600 8N1	9600	8	None	1
Printer	9600 8N2	9600	8	None	2
MODBUS	19200 8N1	19200	8	None	1
Disabled	19200 8N2	19200	8	None	2

COM Port Specs	
Mode	Asynchronous
Transmission	4-wire
Terminator	CR, LF

7.11.1 HyperTerminal

The Variō Pro is compatible with any laptop/PC running the Windows® 98 or later via the built-in HyperTerminal emulation program. To begin a new session, follow these instructions:

1. Connect one end of the Chart/MVE Communications Kit (PN 13376947) to the port labeled *SERIAL I/O* on the bottom of the controller, and the other end to any USB port on the laptop/PC.
2. Confirm that the Variō Pro COM Setup is set to *9600 8N1*, and the COM Type is set to *ASCII*.
3. To open the HyperTerminal program in Windows® XP, go to:

Start → All Programs → Accessories → Communications → HyperTerminal

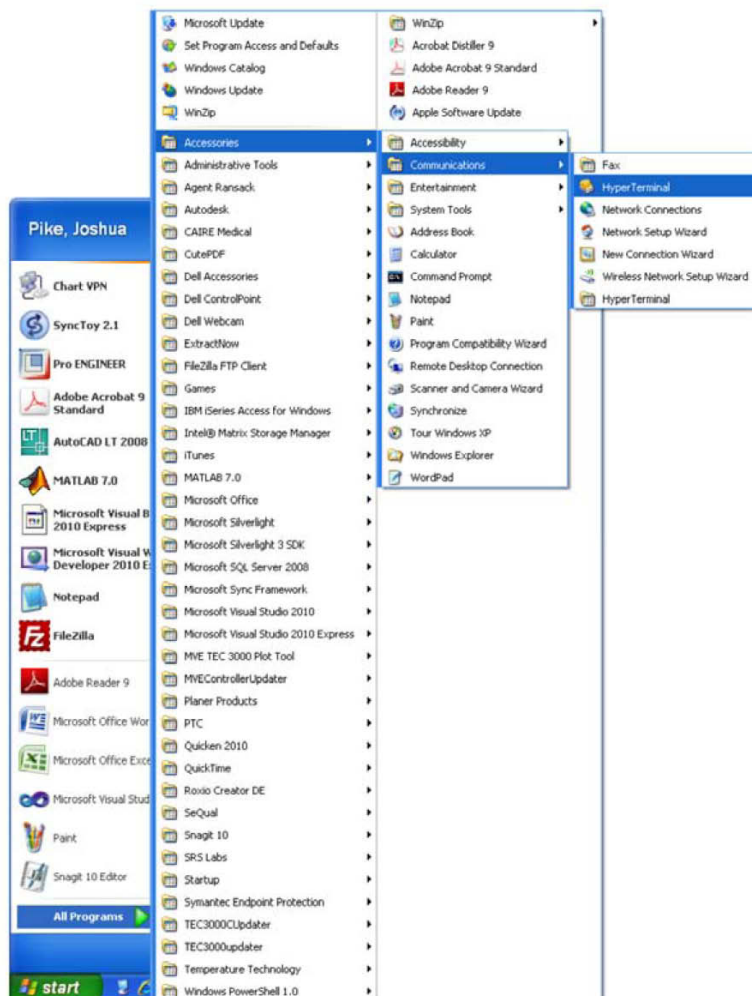

4. HyperTerminal will display a *Connection Description* prompt. Enter a descriptive name for the new connection.



5. At the *Connect To* screen, select the COM port the connection will use.



- In the *Port Properties* dialog, enter the following information and click *Apply*, then press *OK* to close the form:

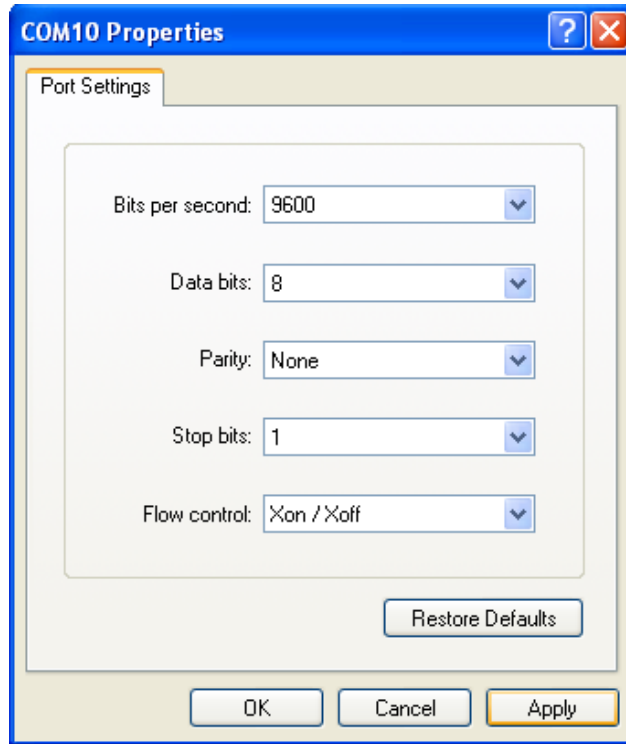

- In the HyperTerminal window, go to *File* and select *Properties*.

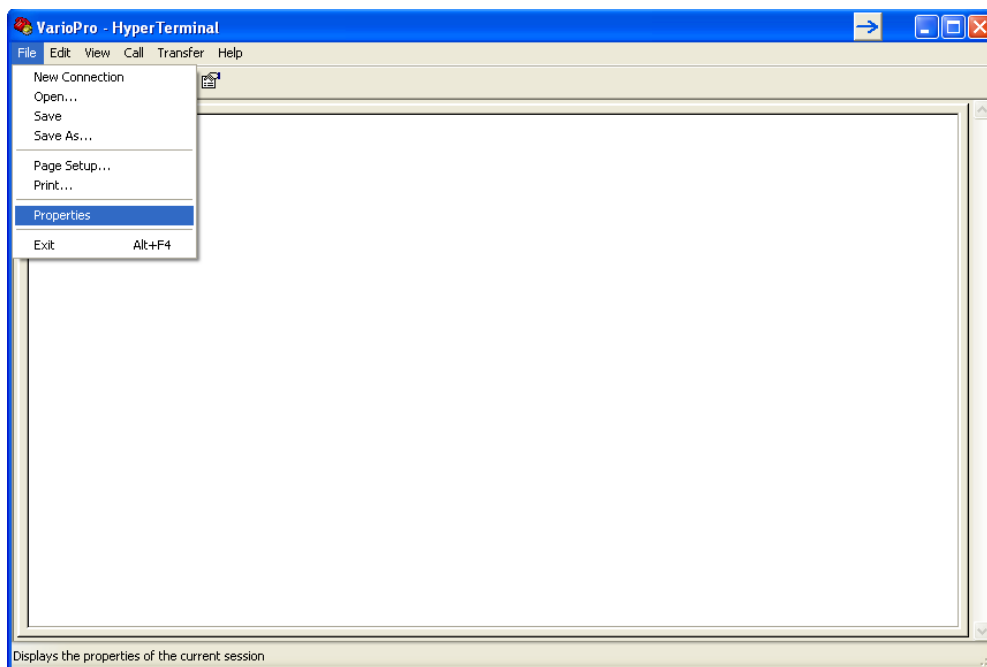

- In the *Properties* window, click the *Settings* tab and enter the information as follows:

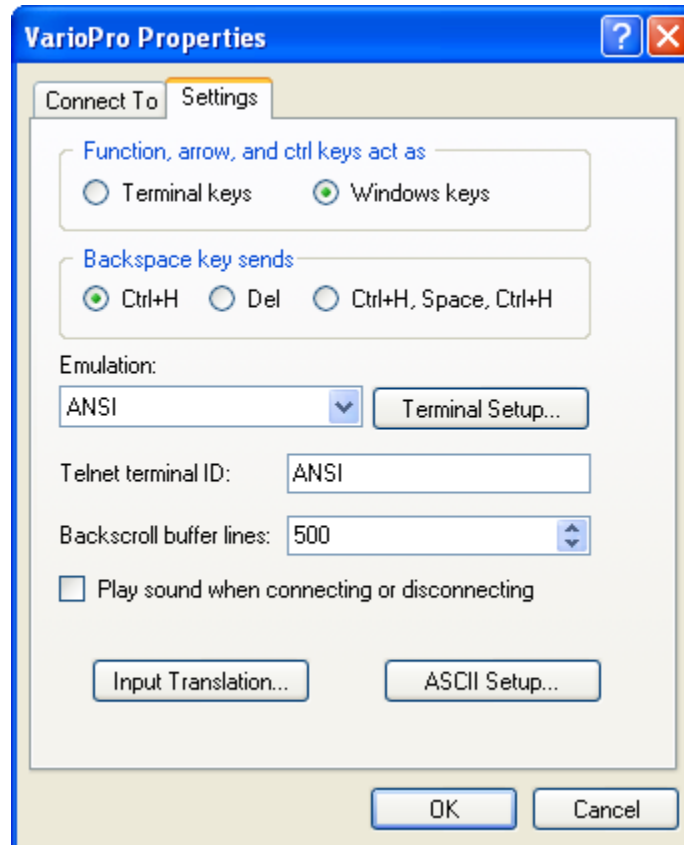

- In the same window, click the *ASCII Setup* button and enter the following information:

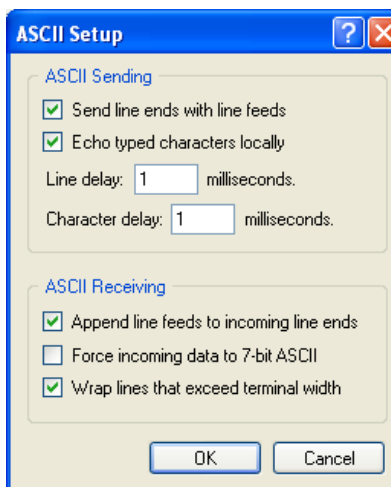

- Press *OK* to close all forms and save your connection. HyperTerminal is now configured and ready for use.



7.11.2 ChartConnect 3000

ChartConnect 3000 is a free, downloadable software program that enables the user to easily download the Variō Pro event log and also monitor various controller parameters. Features include a user-friendly ASCII command window, real-time temperature monitoring, event log download button, and a quick parameter setup table. To download the ChartConnect software and the associated User's Manual, visit:

Software: <http://www.chartbiomed.com/CHARTConnectv112SETUP.zip>

User's Manual: http://www.chartbiomed.com/MNL_USER_CONNECT3000.pdf

For additional information, contact your authorized MVE Distributor or Chart Technical Service.

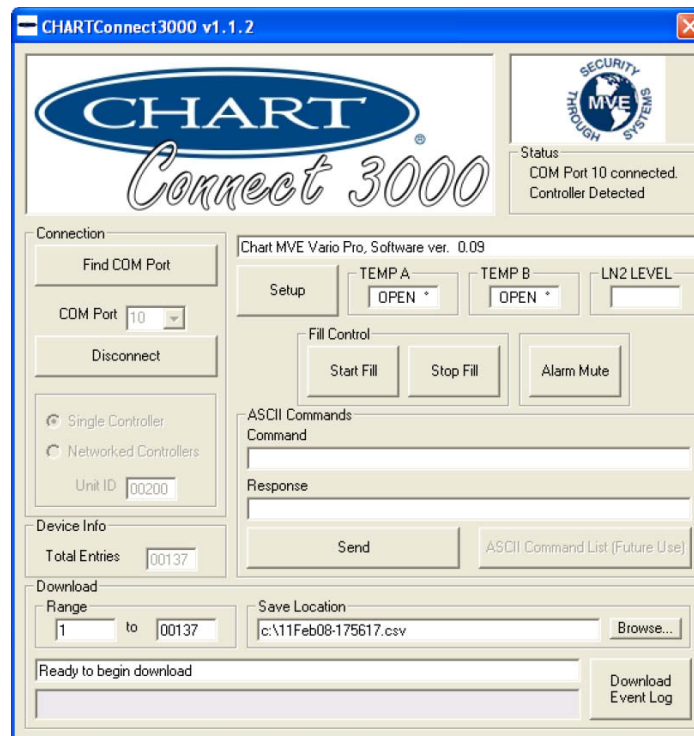

7.11.3 Printer Setup

The MVE Variō Pro compatible printer kit allows the user to print a hard copy of the freezer event log at a set time interval and as events occur. The MVE Variō Pro will print the current status of the freezer in the event log format. The default print interval is 30 minutes.

Note: Adjusting the print interval will not affect the event log interval. These two parameters are independent. The event log interval can be adjusted using ASCII commands. All printed records are not necessarily logged in the event log; however, all the events in the event log are printed.

MVE Controller Printer Kit – PN 11544943

Includes:

- Epson LX-300+II Serial Dot Matrix Printer
- RS-485 Converter and Adapters
- User's Guide

Installation Procedure:

1. Setup printer as described in the included user's guide.
2. Assemble and connect RS-485 converter and adapters as shown below.
3. Connect the printer to MVE Variō Pro serial port via RS-485 converter assembly.
4. Adjust the serial port COM Settings to *9600 8N1* and COM Type to *Printer*.
5. Set the desired print interval.
6. Verify setup by forcing an event or printing a new header.

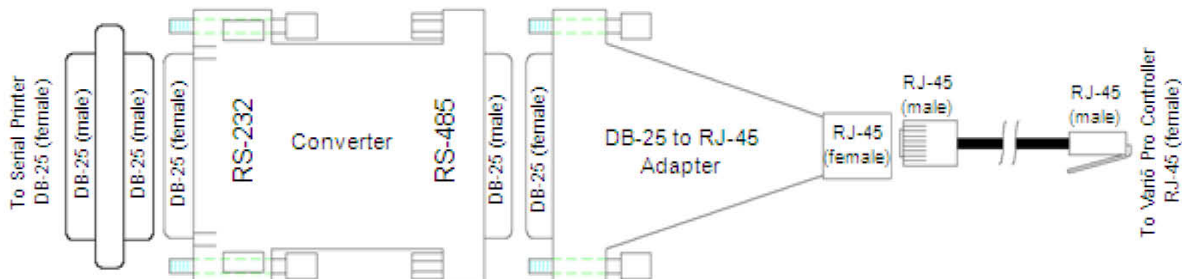



8.0 SYSTEM SETUP & CUSTOMIZATION

8.1 Temperature Settings

8.1.1 Temp Sensors A & B

The default setting for both Temp A and Temp B in *Enabled*, with Temp A functioning as the primary or *driving* sensor. Should Temp A be disabled or otherwise become inoperable for any reason, Temp B will assume the primary role. To adjust the Temp A/B settings, follow these instructions:

1. From the home screen, press *SETUP* to enter setup menus. If Password Entry Mode is enabled, the controller will prompt for a password. Use the ▲/▼ keys to scroll to the appropriate number and press *ENTER* to advance the cursor to the next position.

Higher User Level
Required use ▲▼ to
ENTER Password
0000

2. After entering password, the first menu item is *Temperature Menus*. Press *ENTER*.

Press ENTER for
Temperature menus
or press SETUP for
next menu

3. The first menu item is *Temp A Menu*. For Temp B, press *SETUP* to scroll to *Temp B Menu*. Press *ENTER*.

Press ENTER for
Temp A/B menu
or press SETUP for
next menu

4. The first menu item is the Temp A/B enabling/disabling screen. Use the ▲/▼ keys to adjust, and press *ENTER* to save.

Temp A/B
ENABLED
Use ▼▲ to adjust
Press ENTER to save

5. To initiate a high temperature alarm test for Temp A/B, use the ▲/▼ keys to select *YES* and press *ENTER* to begin, or press *SELECT* to advance to the next screen.

Initiate High Temp A/B
Alarm Test
No
Temp A/B -85.2°C

6. To adjust the Temp A/B high temperature alarm setpoint, use the ▲/▼ to select the desire value and press *ENTER* to save. Press *SETUP* to continue.

Temp A/B High Alarm
-75.0°C
Use ▼▲ to adjust
Press ENTER to save

7. To adjust the Temp A/B low temperature alarm setpoint, use the ▲/▼ to select the desire value and press *ENTER* to save. Press *SETUP* to continue.

Temp A/B Low Alarm
-95.0°C
Use ▼▲ to adjust
Press ENTER to save

8. In the event Temp A/B falls out of calibration, press enter at the *Temp A/B Calibration* display and follow prompts to recalibrate the sensor.

Press ENTER for
Temp A/B Calibration
or press SETUP for
next menu



8.1.2 Chamber Temperature / Coil Outlet Temperature & Deadband

1. From the home screen, press *SETUP* to enter setup menus. If Password Entry Mode is enabled, the controller will prompt for a password. Use the ▲/▼ keys to scroll to the appropriate number and press *ENTER* to advance the cursor to the next position.

Higher User Level
Required use ▲▼ to
ENTER Password
0000

2. After entering password, the first menu item is *Temperature Menus*. Press *ENTER*.

Press ENTER for
Temperature menus
or press SETUP for
next menu

3. Press *SETUP* to scroll to the *Cooling Menu* display and press *ENTER*.

Press ENTER for
Cooling menu
or press SETUP for
next menu

4. The first menu item will display the current temperature of the cooling temp sensor. Press *SETUP* to continue.

Current Cooling Temp
-60.0°C

5. To adjust the maximum (warmest) allowable chamber temperature, use the ▲/▼ keys to select the desired value and press *ENTER* to save. Press *SETUP* to advance to the next screen.

Note: The Variō Pro controller will not allow the user to select a maximum chamber temp greater than or equal to the high temperature alarm setpoint. As a result, it may be necessary to adjust the high temperature alarm prior to changing the maximum chamber temp.

Max Chamber Temp
-80.0°C
Use ▼▲ to adjust
Press ENTER to save

6. To adjust the chamber temperature deadband, use the ▲/▼ keys to select the desired value and press *ENTER* to save. Note that the chamber deadband also defines the minimum (coldest) allowable chamber temperature.

Note: The Variō Pro controller will not allow the user to select a maximum chamber temp / chamber deadband combination that results in a minimum chamber temp less than or equal to the low temperature setpoint. As a result, it may be necessary to adjust the low temp alarm prior to changing the chamber deadband.

Chamber Deadband
10.0°C
Use ▼▲ to adjust
Press ENTER to save

7. The minimum coil outlet temperature defines the coldest allowable temperature of the N₂ as it exits the heat exchanger coil. The default value of -60.0°C is sufficient to maintain chamber temperatures as cold as -150.0°C.

Min Coil outlet temp
-60.0°C
Use ▼▲ to adjust
Press ENTER to save

8. The coil outlet deadband, when added to the minimum coil outlet temp, defines the warmest allowable temperature of the N₂ before it is purged out of the heat exchanger coil and into the freezer. The default value of 10.0°C is sufficient to maintain chamber temperatures as cold as -150.0°C.

Coil outlet deadband
10.0°C
Use ▼▲ to adjust
Press ENTER to save

9. To enable/disable the cooling time alarm, use the ▲/▼ keys to change selection and press *ENTER* to save. Press *SETUP* to advance to the next screen.

Cooling Time Alarm
ENABLED
Use ▼▲ to adjust
Press ENTER to save



10. To adjust the cooling time alarm delay, use the ▲/▼ keys to select the desired value and press ENTER to save. Press SETUP to advance to the next screen.

Cooling Time Alarm Delay
240 min
Use ▼▲ to adjust
Press ENTER to save

11. In the event the cooling temp sensor falls out of calibration, press enter at the *Coil temp Cal* display and follow prompts to recalibrate the sensor.

Press ENTER for
Coil temp Cal
or press SETUP for
next menu

8.1.3 Inlet Temperature & Bypass Cycle

1. From the home screen, press SETUP to enter setup menus. If Password Entry Mode is enabled, the controller will prompt for a password. Use the ▲/▼ keys to scroll to the appropriate number and press ENTER to advance the cursor to the next position.

Higher User Level
Required use ▲▼ to
ENTER Password
0000

2. After entering password, the first menu item is *Temperature Menus*. Press ENTER.

Press ENTER for
Temperature menus
or press SETUP for
next menu

3. Press SETUP to scroll to the *Inlet Temp Menus* display and press ENTER.

Press ENTER for
Cooling menu
or press SETUP for
next menu

4. The first menu item will display the current temperature of the inlet temp sensor. Press SETUP to continue.

Current Inlet Temp
20.0°C

5. To enable/disable the bypass cycle - and thus the supply alarm - use the ▲/▼ keys to change selection and press ENTER to save. Press SETUP to advance to the next screen.

Gas Bypass & Supply Alarm
ENABLED
Use ▼▲ to adjust
Press ENTER to save

6. The inlet temp setpoint defines the warmest allowable temperature at which N₂ will be introduced to the heat exchanger coils. The default value of -70°C is suitable for most applications.

Inlet Temp Setpoint
-70.0°C
Use ▼▲ to adjust
Press ENTER to save

7. The supply alarm delay defines the maximum amount of time the bypass cycle will run before being terminated and a supply alarm being triggered. To adjust, use the ▲/▼ keys to select the desired value and press ENTER to save. Press SETUP to advance to the next screen.

Supply Alarm Delay
5 min
Use ▼▲ to adjust
Press ENTER to save

Note: The supply time will vary significantly from one application to another. It is recommended that the user observe and record several bypass cycles in order to establish a typical supply time for the application, and adjust the supply alarm delay accordingly.

8. To enable/disable the stuck valve alarms, use the ▲/▼ keys to change selection and press ENTER to save. Press SETUP to advance to the next screen.

Stuck Valve Alarm
ENABLED
Use ▼▲ to adjust
Press ENTER to save



- 9. To adjust the valve stuck open time delay, use the ▲/▼ keys to select the desired value and press *ENTER* to save. Press *SETUP* to advance to the next screen.

Stuck Open Delay
30 min
Use ▼▲ to adjust
Press ENTER to save

- 10. To adjust the valve stuck closed time delay, use the ▲/▼ keys to select the desired value and press *ENTER* to save. Press *SETUP* to advance to the next screen.

Stuck Closed Delay
30 min
Use ▼▲ to adjust
Press ENTER to save

- 11. In the event the inlet temp sensor falls out of calibration, press enter at the *Inlet Calibration* display and follow the prompts to recalibrate the sensor.

Press ENTER for
Inlet Calibration
or press SETUP
for next menu

8.1.4 Setting Liquid Nitrogen Temperature

- 1. From the home screen, press *SETUP* to enter setup menus. If Password Entry Mode is enabled, the controller will prompt for a password. Use the ▲/▼ keys to scroll to the appropriate number and press *ENTER* to advance the cursor to the next position.

Higher User Level
Required use ▲▼ to
ENTER Password
0000

- 2. After entering password, the first menu item is *Temperature Menus*. Press *ENTER*.

Press ENTER for
Temperature menus
or press SETUP for
next menu

- 3. Press *SETUP* repeatedly to scroll through menu items. When the *LN2 Temperature* screen appears, use the ▲/▼ keys to adjust the setting to the appropriate value. Press *ENTER* to save setting.

LN2 Temperature
-196.2°C
Use ▼▲ to adjust
Press ENTER to save

Note: LN2 saturation temperatures at various altitudes are shown below.

- 4. Controller will accept change and display confirmation screen.

NEW SETTING ACCEPTED

LN2 Saturation Temp vs. Altitude				
Altitude		LN2 Saturation Temperature		
Meters	Feet	°C	°F	K
0 – 152	0 – 500	-195.8	-320.4	77.4
152 – 305	501 – 1000	-196.0	-320.7	77.2
305 – 457	1000 – 1500	-196.2	-321.1	77.0
457 – 610	1501 – 2000	-196.4	-321.5	76.8
610 – 915	2001 – 3000	-196.6	-321.9	76.6
915 – 1220	3001 – 4000	-196.9	-322.4	76.3
1220 – 1524	4001 – 5000	-197.2	-322.9	76.0
1524 – 1829	5001 – 6000	-197.5	-323.5	75.7
1829 – 2134	6001 – 7000	-197.8	-324.0	75.4
2134 – 2439	7001 – 8000	-198.1	-324.6	75.1
2439 – 2744	8001 – 9000	-198.4	-325.1	74.8
2744 – 3049	9001 – 10000	-198.7	-325.7	74.4



8.2 Battery Backup

Once the battery backup has been connected, the Variō Pro controller will automatically detect its presence and enable its use accordingly. There is no need to manually enable the battery backup, and the only way to disable its use is to physically remove it from the controller. To check the operating status of the battery backup, follow these instructions:

1. From the home screen, press *SETUP* to enter setup menus. If Password Entry Mode is enabled, the controller will prompt for a password. Use the ▲/▼ keys to scroll to the appropriate number and press *ENTER* to advance the cursor to the next position.
2. After entering password, the first menu item is *Temperature Menus*. Press *SETUP* to scroll through the menu items. When the *Add-on Menus* screen is displayed, press *ENTER*.
3. The first menu item is the controller power status. If the controller is being powered by the battery backup, the screen will display *On Battery Backup*, the current battery voltage, and the charge level as a percentage. Otherwise, the screen will display *On AC Power*.

Higher User Level
Required use ▲▼ to
ENTER Password
0000

Press ENTER for
Add-on menus
or press SETUP for
next menu

Power Status
On Battery Backup
27VDC
100%

Power Status
On AC Power



8.3 Lid Switch

1. From the home screen, press *SETUP* to enter setup menus. If Password Entry Mode is enabled, the controller will prompt for a password. Use the ▲/▼ keys to scroll to the appropriate number and press *ENTER* to advance the cursor to the next position.
2. After entering password, press *SETUP* to scroll through the menu items. When the *Add-on menus* screen appears, press *ENTER*.
3. The first menu item is the controller Power Status menu. Press *SETUP* to scroll to the Lid Switch menus and press *ENTER*.
4. The first menu item is the *Lid Switch Installed* display. Use the ▲/▼ keys to select *YES* or *NO*. Press *ENTER* to save.
5. Press *SETUP* to scroll to the *Automatic Fog Clear* menu and adjust setting to the desired value. Press *ENTER* to save.
6. Press *SETUP* to scroll to the *Lid Open Alarm Time* menu and adjust setting to the desired value. Press *ENTER* to save.

Higher User Level
Required use ▲▼ to
ENTER Password
0000

Press ENTER for
Add-on menus
or press SETUP for
next menu

Press ENTER for
Lid Switch menus
or press SETUP for
next menu

Lid Switch Installed
NO
Use ▼▲ to adjust
Press ENTER to save

Automatic Fog Clear
DISABLED
Use ▲▼ to adjust
Press ENTER to save

Lid Open Alarm Time
5 min
Use ▲▼ to adjust
Press ENTER to save



8.4 Controller Display & Output

8.4.1 Temperature Units

1. From the home screen, press *SETUP* to enter setup menus. If Password Entry Mode is enabled, the controller will prompt for a password. Use the ▲/▼ keys to scroll to the appropriate number and press *ENTER* to advance the cursor to the next position.
2. After entering password, press *SETUP* to scroll through the menu items. When the *Display and Output* screen appears, press *ENTER*.
3. The first menu item is the *Temperature Units* screen. Use the ▲/▼ keys to select either °C, °F, or K. Press *ENTER* to save.

Higher User Level
Required use ▲▼ to
ENTER Password
0000

Press ENTER for
Display and Output
or press SETUP for
next menu

Temperature Units
°C
Use ▲▼ to adjust
Press ENTER to save

8.4.2 Alarm Buzzer

1. From the home screen, press *SETUP* to enter setup menus. If Password Entry Mode is enabled, the controller will prompt for a password. Use the ▲/▼ keys to scroll to the appropriate number and press *ENTER* to advance the cursor to the next position.
2. After entering password, press *SETUP* to scroll through the menu items. When the *Display and Output* screen appears, press *ENTER*.
3. Press *SETUP* to scroll to the *Advanced Display and Output* menu and press *ENTER*.
4. The first menu item is the *Alarm Buzzer* menu. Use the ▲/▼ keys to enable/disable the audible alarm buzzer. Press *ENTER* to save.

Higher User Level
Required use ▲▼ to
ENTER Password
0000

Press ENTER for
Display and Output
or press SETUP for
next menu

Press ENTER for
Advanced Display
and Output or press SETUP
for next menu

Alarm Buzzer
ENABLED
Use ▲▼ to adjust
Press ENTER to save



8.4.3 Language Settings

1. From the home screen, press *SETUP* to enter setup menus. If Password Entry Mode is enabled, the controller will prompt for a password. Use the ▲/▼ keys to scroll to the appropriate number and press *ENTER* to advance the cursor to the next position.
2. After entering password, press *SETUP* to scroll through the menu items. When the *Display and Output* screen appears, press *ENTER*.
3. Press *SETUP* to scroll to the *Advanced Display and Output* menu and press *ENTER*.
4. Press *SETUP* scroll to the *Language* menu. Use the ▲/▼ keys to select either English, French, Italian, German, or Spanish. Press *ENTER* to save.

Higher User Level
Required use ▲▼ to
ENTER Password
0000

Press ENTER for
Display and Output
or press SETUP for
next menu

Press ENTER for
Advanced Display
and Output or press SETUP
for next menu

Language
ENGLISH
Use ▲▼ to adjust
Press ENTER to save

8.4.4 Printer Settings

1. From the home screen, press *SETUP* to enter setup menus. If Password Entry Mode is enabled, the controller will prompt for a password. Use the ▲/▼ keys to scroll to the appropriate number and press *ENTER* to advance the cursor to the next position.
2. After entering password, press *SETUP* to scroll through the menu items. When the *Display and Output* screen appears, press *ENTER*.
3. Press *SETUP* to scroll to the *Advanced Display and Output* menu and press *ENTER*.
4. Press *SETUP* to scroll to the *Printer* menus and press *ENTER*.
5. The first menu item is the *Print Interval* menu. Use the ▲/▼ keys to adjust setting to the desire value and press *ENTER* to save.

Higher User Level
Required use ▲▼ to
ENTER Password
0000

Press ENTER for
Display and Output
or press SETUP for
next menu

Press ENTER for
Advanced Display
and Output or press SETUP
for next menu

Press ENTER for
Printer menus
or press SETUP for
next menu

Print interval
30 min
Use ▲▼ to adjust
Press ENTER to save



8.5 Security Setup

8.5.1 Password Entry Mode

1. From the home screen, press *SETUP* to enter setup menus. If Password Entry Mode is enabled, the controller will prompt for a password. Use the ▲/▼ keys to scroll to the appropriate number and press *ENTER* to advance the cursor to the next position.
2. After entering password, press *SETUP* to scroll through the menu items. When the *Password Menus* screen appears, press *ENTER*.
3. The controller will prompt for a password. Use the ▲/▼ keys to scroll to the appropriate number and press *ENTER* to advance the cursor to the next position.
4. The first menu item is the *Password Entry Mode* display. Use the ▲/▼ keys to enable/disable password entry mode and press *ENTER* to save.

Higher User Level
Required use ▲▼ to
ENTER Password
0000

Press ENTER for
Password menus
or press SETUP for
next menu

Higher User Level
Required use ▲▼ to
ENTER Password
0000

Password Entry Mode
ENABLED
Use ▲▼ to adjust
Press ENTER to save

8.5.2 Global Password

1. From the home screen, press *SETUP* to enter setup menus. If Password Entry Mode is enabled, the controller will prompt for a password. Use the ▲/▼ keys to scroll to the appropriate number and press *ENTER* to advance the cursor to the next position.
2. After entering password, press *SETUP* to scroll through the menu items. When the *Password Menus* screen appears, press *ENTER*.
3. The controller will prompt for a password. Use the ▲/▼ keys to scroll to the appropriate number and press *ENTER* to advance the cursor to the next position.
4. Press *SETUP* to scroll to the *Change Global Password* display and press *ENTER*.
5. Use the ▲/▼ keys to scroll to the desired number and press *ENTER* to advance the cursor to the next position. When complete, press *ENTER* to save.
6. At the *Confirm New Password?* display, use the ▲/▼ keys to select either *YES* to confirm, or *NO* to cancel. Press *ENTER* to save.

Higher User Level
Required use ▲▼ to
ENTER Password
0000

Press ENTER for
Password menus
or press SETUP for
next menu

Higher User Level
Required use ▲▼ to
ENTER Password
0000

Press ENTER to
Change global
Password or press SETUP
for next menu

Global Password
Use ▲▼ to adjust
Press ENTER for next
XXXX

Confirm new
Password?
NO
Use ▲▼ to adjust



8.5.3 Multilevel Passwords

1. From the home screen, press *SETUP* to enter setup menus. If Password Entry Mode is enabled, the controller will prompt for a password. Use the ▲/▼ keys to scroll to the appropriate number and press *ENTER* to advance the cursor to the next position.
2. After entering password, press *SETUP* to scroll through the menu items. When the *Password Menus* screen appears, press *ENTER*.
3. The controller will prompt for a password. Use the ▲/▼ keys to scroll to the appropriate number and press *ENTER* to advance the cursor to the next position.
4. Press *SETUP* to scroll to the *Change Password 1* display and press *ENTER*.
5. Use the ▲/▼ keys to scroll to the desired number and press *ENTER* to advance the cursor to the next position. When complete, press *ENTER* to save.
6. At the *Password 1 Level* display, use the ▲/▼ keys to select the desired access level for password 1.
7. At the *Confirm New Password?* display, use the ▲/▼ keys to select either *YES* to confirm, or *NO* to cancel. Press *ENTER* to save.

Higher User Level
Required use ▲▼ to
ENTER Password
0000

Press ENTER for
Password menus
or press SETUP for
next menu

Higher User Level
Required use ▲▼ to
ENTER Password
0000

Press ENTER to
Change Password 1
or press SETUP for
next menu

Password 1
Use ▲▼ to adjust
Press ENTER for next
XXXX

Password 1 level
Use ▲▼ to adjust
Press ENTER for next
1

Confirm new
Password?
NO
Use ▲▼ to adjust

Security Access Levels			
LEVEL 1	LEVEL 2	LEVEL 3	LEVEL 4
<ul style="list-style-type: none"> ▪ Fog Clear ▪ End Clear ▪ Alarm Mute ▪ Change Display Units 	Level 1 + : <ul style="list-style-type: none"> ▪ Temp Settings ▪ Time & Date Settings ▪ Calibration Menus ▪ Language Selection ▪ Hot Gas Bypass Menus 	Level 2 + : <ul style="list-style-type: none"> ▪ Communications Settings ▪ Programming 	Level 3 + : <ul style="list-style-type: none"> ▪ Password Settings



Forgot your password? Contact your authorized MVE Distributor or the Chart-MVE Technical Service group.



8.6 Advanced Settings

8.6.1 Date & Time Adjustment

1. From the home screen, press *SETUP* to enter setup menus. If Password Entry Mode is enabled, the controller will prompt for a password. Use the ▲/▼ keys to scroll to the appropriate number and press *ENTER* to advance the cursor to the next position.

Higher User Level
Required use ▲▼ to
ENTER Password
0000

2. After entering password, press *SETUP* to scroll to the *Advanced Settings* menu and press *ENTER*.

Press ENTER for
Advanced settings
or press SETUP for
next menu

3. The first menu item is the *Set Time and Date* display. Press *ENTER*.

Press ENTER for
Set Time and Date
or press SETUP for
next menu

4. Use the ▲/▼ keys to enter the current hour. Press *ENTER* to save or *SETUP* to advance to the next screen.

Hour
01:47
Use ▲▼ to adjust
Press ENTER to save

5. Use the ▲/▼ keys to enter the current minute. Press *ENTER* to save or *SETUP* to advance to the next screen.

Minute
01:47
Use ▲▼ to adjust
Press ENTER to save

6. Use the ▲/▼ keys to enter the current year. Press *ENTER* to save or *SETUP* to advance to the next screen.

Year
2011
Use ▲▼ to adjust
Press ENTER to save

7. Use the ▲/▼ keys to enter the current month. Press *ENTER* to save or *SETUP* to advance to the next screen.

Month
1
Use ▲▼ to adjust
Press ENTER to save

8. Use the ▲/▼ keys to enter the current day. Press *ENTER* to save or *SETUP* to advance to the next screen.

Day
1
Use ▲▼ to adjust
Press ENTER to save

9. Use the ▲/▼ keys to select either the 12 or 24 hour time format. Press *ENTER* to save or *SETUP* to advance to the next screen.

Time Format
12:00
Use ▲▼ to adjust
Press ENTER to save

10. Use the ▲/▼ keys to select the desired date format. Press *ENTER* to save or *SETUP* to return to the *Hour* display.

Date Format
MM/DD/YY
Use ▲▼ to adjust
Press ENTER to save



8.6.2 Communications

8.6.2.1 COM Setup

1. From the home screen, press *SETUP* to enter setup menus. If Password Entry Mode is enabled, the controller will prompt for a password. Use the ▲/▼ keys to scroll to the appropriate number and press *ENTER* to advance the cursor to the next position.
2. After entering password, press *SETUP* to scroll to the *Advanced Settings* menu and press *ENTER*.
3. Press *SETUP* to scroll to the *COM 1 Menus* and press *ENTER*.
4. The first menu item is the *COM 1 Setup* display. Use the ▲/▼ keys to select the desired protocol. Press *ENTER* to save or *SETUP* to advance to the *COM 1 Type* display.

Higher User Level
Required use ▲▼ to
ENTER Password
0000

Press ENTER for
Advanced settings
or press SETUP for
next menu

Press ENTER for
Com 1 menus
or press SETUP for
next menu

Com 1 Setup
9600 8N1
Use ▲▼ to adjust
Press ENTER to save

8.6.2.2 COM Type

1. From the home screen, press *SETUP* to enter setup menus. If Password Entry Mode is enabled, the controller will prompt for a password. Use the ▲/▼ keys to scroll to the appropriate number and press *ENTER* to advance the cursor to the next position.
2. After entering password, press *SETUP* to scroll to the *Advanced Settings* menu and press *ENTER*.
3. Press *SETUP* to scroll to the *COM 1 Menu* and press *ENTER*.
4. Press *SETUP* to scroll to the *COM 1 Type* display and press *ENTER*. Use the ▲/▼ keys to enter the desired communication type. Press *ENTER* to save or *SETUP* to return to the *COM 1 Setup* screen.

Higher User Level
Required use ▲▼ to
ENTER Password
0000

Press ENTER for
Advanced settings
or press SETUP for
next menu

Press ENTER for
Com 1 menus
or press SETUP for
next menu

Com 1 Type
ASCII
Use ▲▼ to adjust
Press ENTER to save



8.6.3 Unit ID / Modbus Menu

1. From the home screen, press *SETUP* to enter setup menus. If Password Entry Mode is enabled, the controller will prompt for a password. Use the ▲/▼ keys to scroll to the appropriate number and press *ENTER* to advance the cursor to the next position.
2. After entering password, press *SETUP* to scroll to the *Advanced Settings* menu and press *ENTER*.
3. Press *SETUP* to scroll to the *MODBUS Menu* and press *ENTER*.
4. Use the ▲/▼ keys to enter the desired Unit ID. Press *ENTER* to save or *ESC* to return to the previous screen.

Higher User Level
Required use ▲▼ to
ENTER Password
0000

Press ENTER for
Advanced settings
or press SETUP for
next menu

Press ENTER for
MODBUS menu
or press SETUP for
next menu

Unit ID
1
Use ▲▼ to adjust
Press ENTER to save

8.6.4 Restoring Manufacturer Defaults

1. From the home screen, press *SETUP* to enter setup menus. If Password Entry Mode is enabled, the controller will prompt for a password. Use the ▲/▼ keys to scroll to the appropriate number and press *ENTER* to advance the cursor to the next position.
2. After entering password, press *SETUP* to scroll to the *Advanced Settings* menu and press *ENTER*.
3. Press *SETUP* to scroll to the *Restore All Defaults* screen and press *ENTER*.
4. Use the ▲/▼ keys to select either *YES* to confirm, or *NO* to cancel. Press *ENTER* to save or *ESC* to return to the previous screen.

Higher User Level
Required use ▲▼ to
ENTER Password
0000

Press ENTER for
Advanced settings
or press SETUP for
next menu

Press ENTER to
Restore All Defaults
or press SETUP for
next menu

Confirm Restore
NO
Use ▲▼ to adjust
Press ENTER to save



8.6.5 Restarting the Controller

1. From the home screen, press *SETUP* to enter setup menus. If Password Entry Mode is enabled, the controller will prompt for a password. Use the ▲/▼ keys to scroll to the appropriate number and press *ENTER* to advance the cursor to the next position.
2. After entering password, press *SETUP* to scroll to the *Advanced Settings* menu and press *ENTER*.
3. Press *SETUP* to scroll to the *Restore All Defaults* screen and press *ENTER*.
4. Use the ▲/▼ keys to select either *YES* to confirm, or *NO* to cancel. Press *ENTER* to save or *ESC* to return to the previous screen.

Higher User Level
Required use ▲▼ to
ENTER Password
0000

Press ENTER for
Advanced settings
or press SETUP for
next menu

Press ENTER to
Restart Controller
or press SETUP for
next menu

Confirm Restart
YES
Use ▲▼ to adjust
Press ENTER to save

Note: The controller may briefly display a *Communications Loss* error screen during the restart cycle. This is normal and occurs because the display remains active while the controller reboots.

Communications
Loss Unit 1
Started/Ended at:
01/1/11 12:00

9.0 MVE VARIŌ PRO MENU MAPS

9.1 Setup Menus

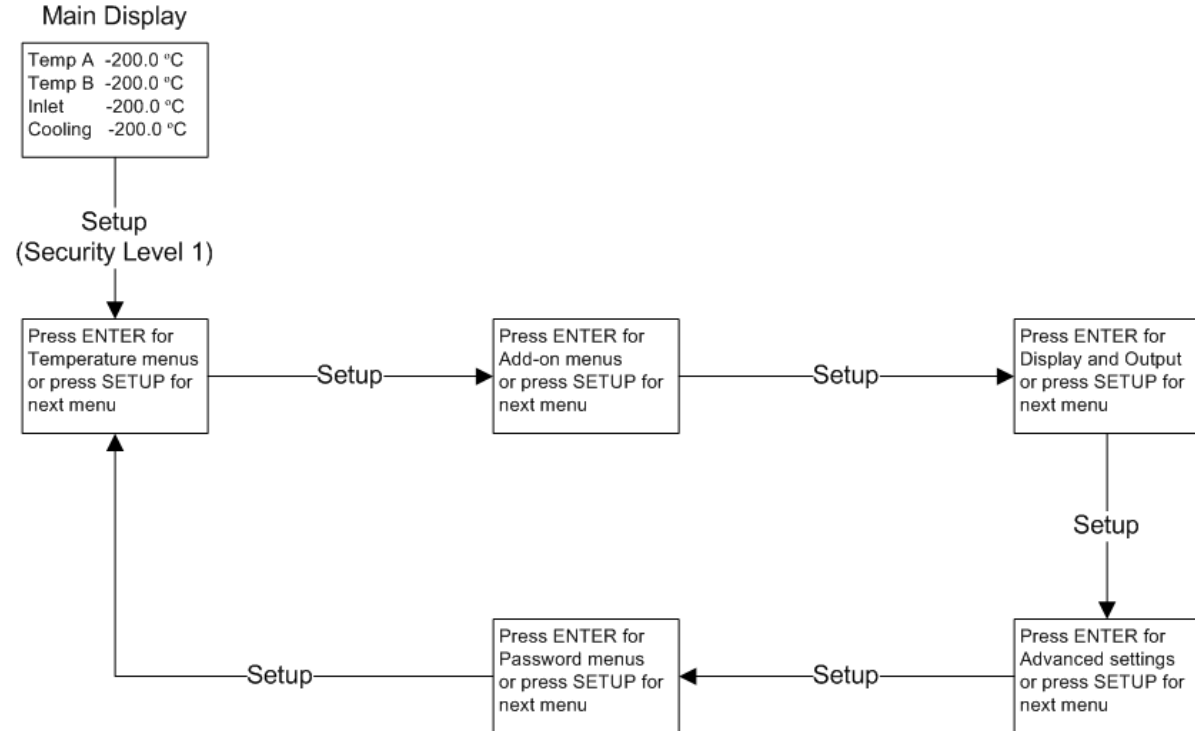

9.2 Temperature Menus

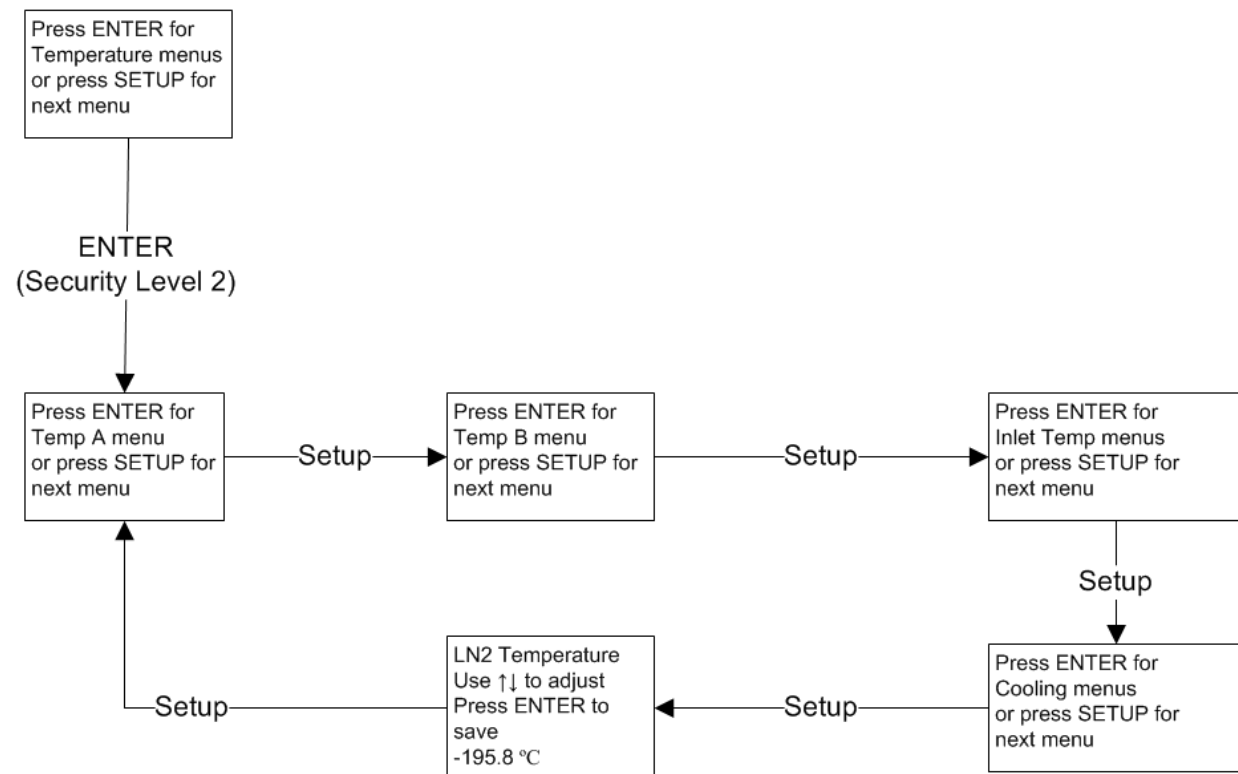

9.3 Temp A & B Menus

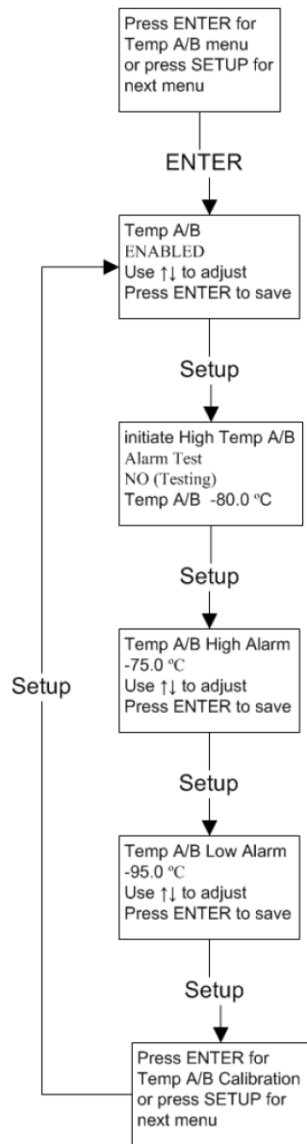

9.4 Inlet Temp Menu

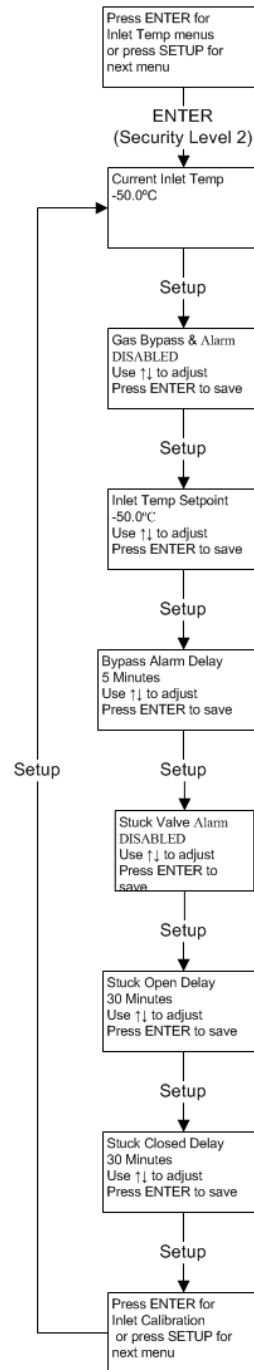



9.5 Cooling Temp Menus

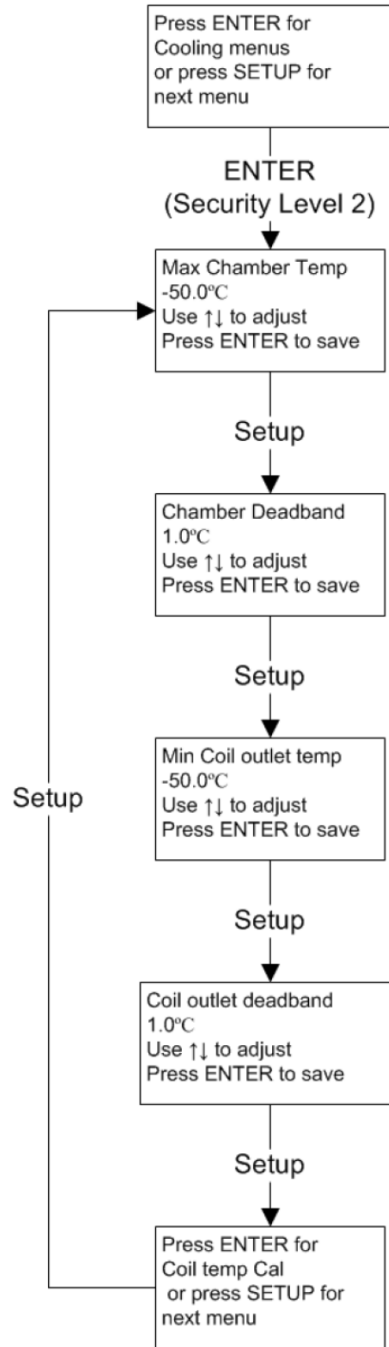

9.6 Calibration Menus

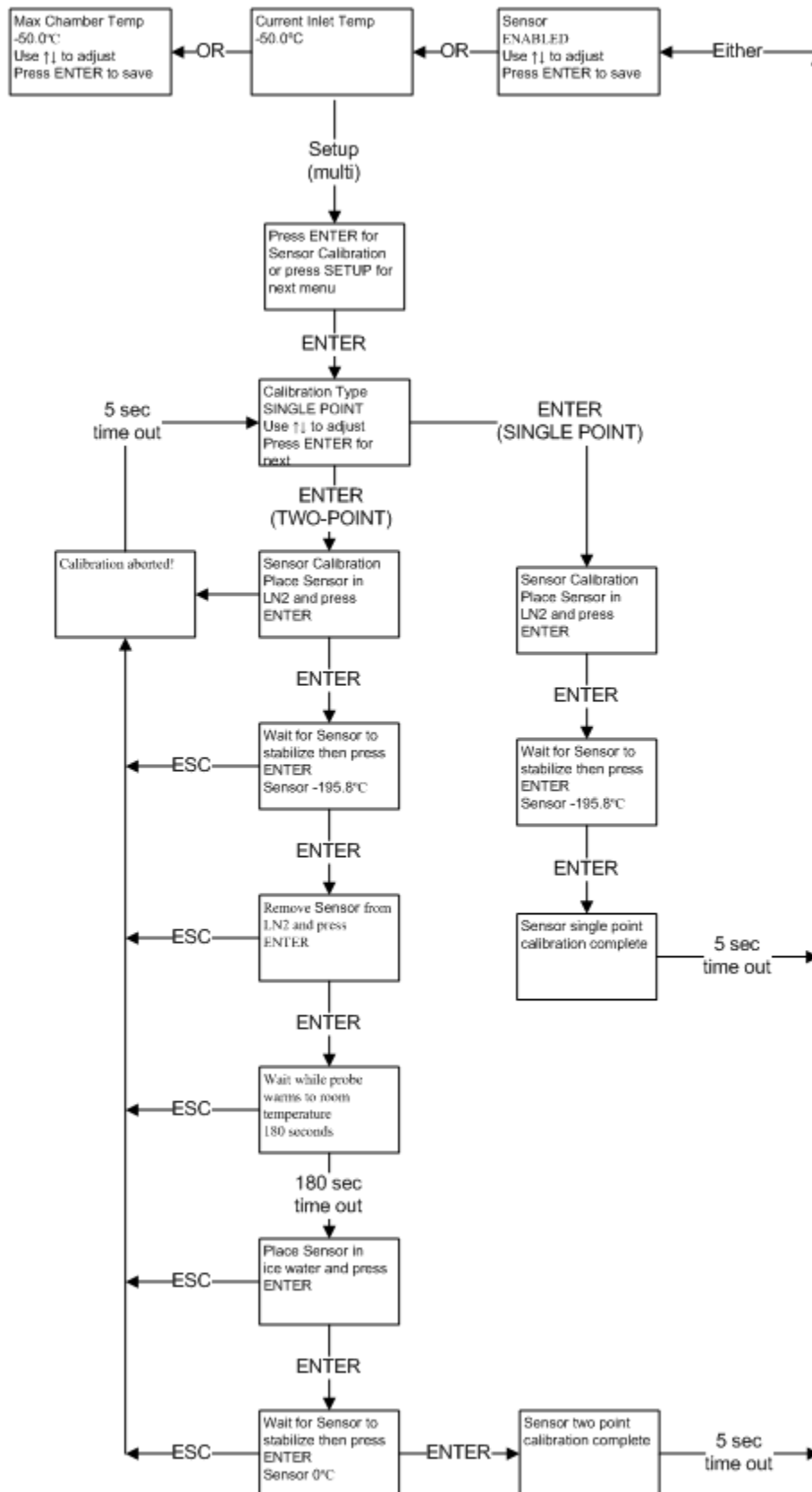

9.7 Add-on Menus

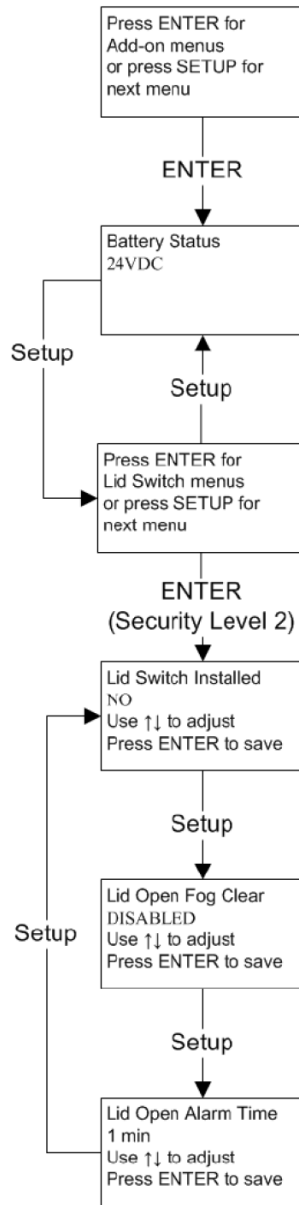

9.8 Display & Output

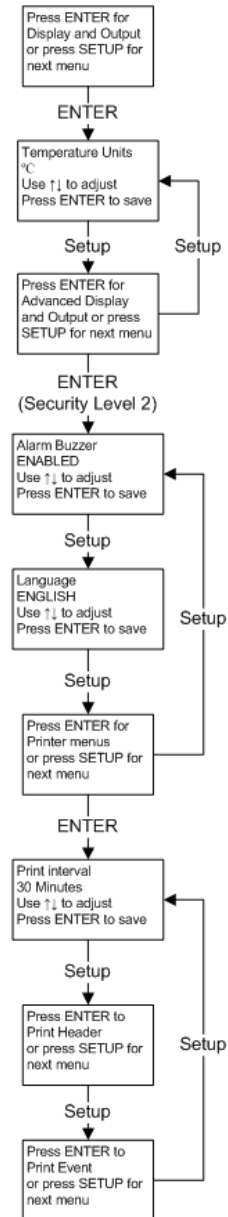

9.9 Advanced Settings

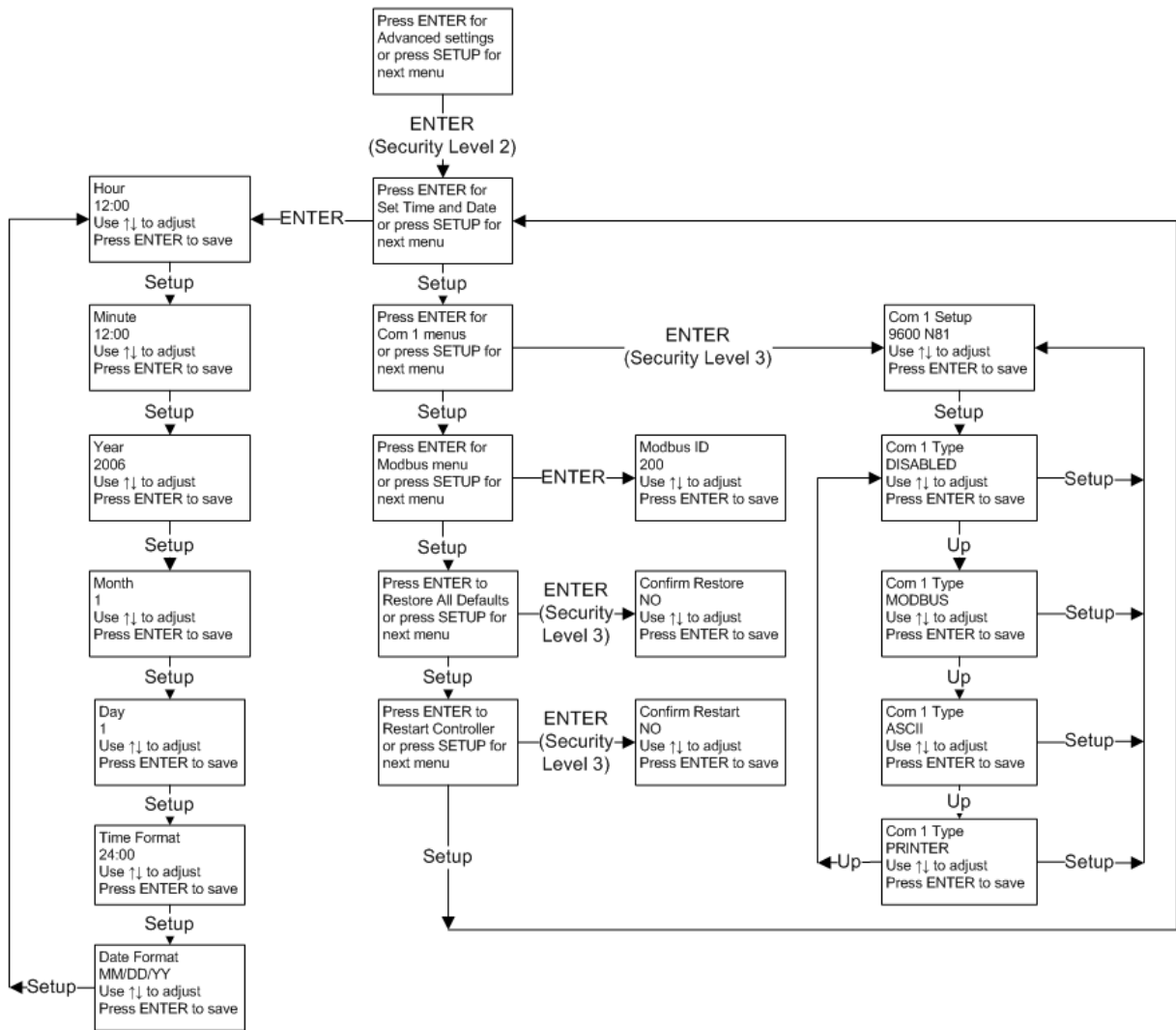

9.10 Password Menus

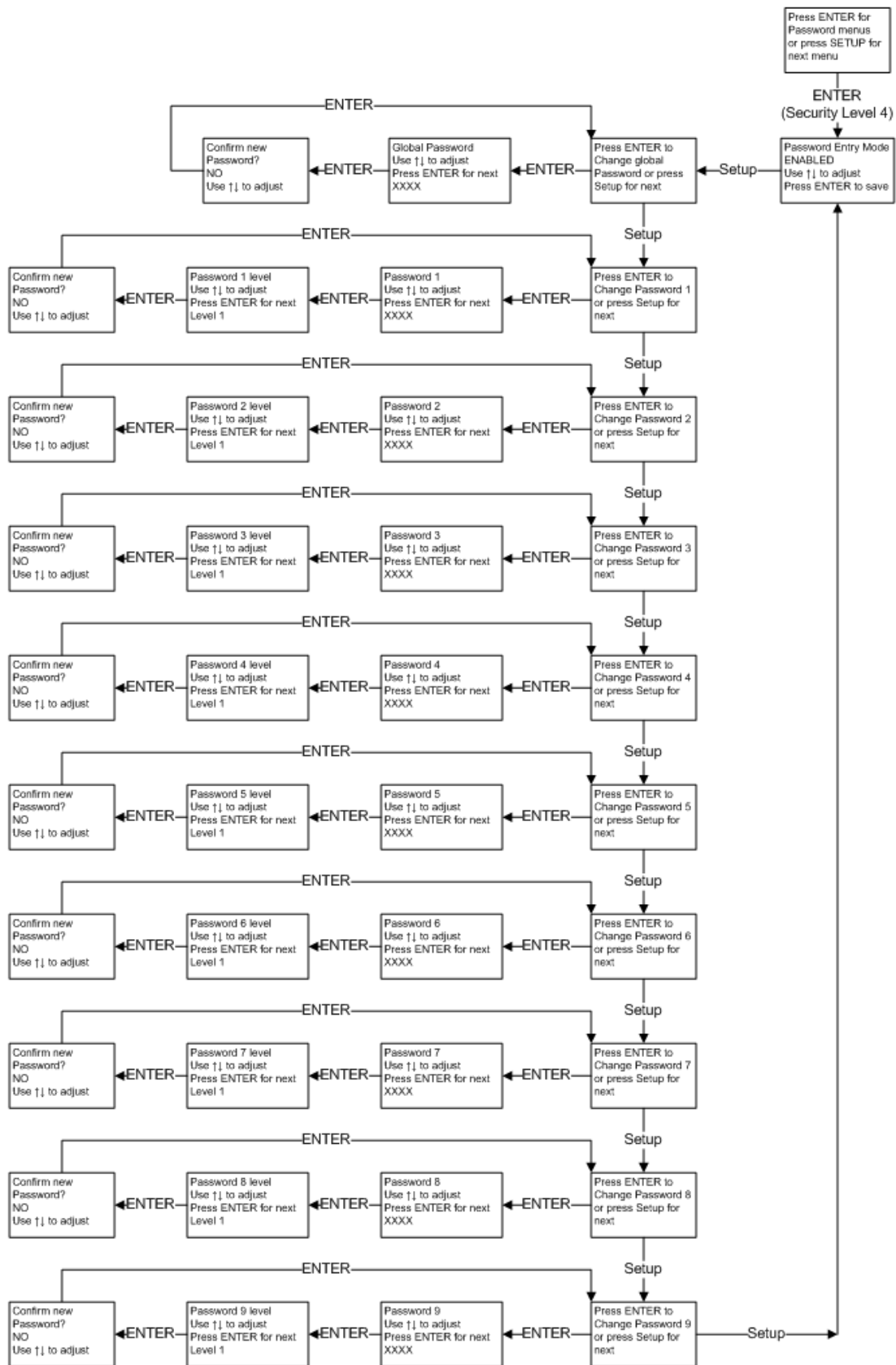



9.11 MVE Variō Pro Display Screens

9.11.1 Power Up & Main Displays

Starting
Please Wait
Version:
0.01

Temp A -200.0 °C
Temp B -200.0 °C
Inlet -200.0 °C
Cooling -200.0 °C

9.11.2 Alarm & Status Displays

ALARM
High Temp A
Started/Ended at:
11/25/05 15:30

ALARM
High Temp B
Started/Ended at:
11/25/05 15:30

ALARM
Temp A Sensor Fail
Started/Ended at:
11/25/05 15:30

ALARM
Temp B Sensor Fail
Started/Ended at:
11/25/05 15:30

ALARM
Low Temp A
Started/Ended at:
11/25/05 15:30

ALARM
Low Temp B
Started/Ended at:
11/25/05 15:30

ALARM
Inlet Sensor Fail
Started/Ended at:
11/25/05 15:30

ALARM
Cooling Sensor Fail
Started/Ended at:
11/25/05 15:30

ALARM
Bypass Time 5 min
Started/Ended at:
11/25/05 15:30

ALARM
Lid Open 30 min
Started/Ended at:
11/25/05 15:30

ALARM
Cooling Time 60 min
Started/Ended at:
11/25/05 15:30

ALARM
Low Battery
Started/Ended at:
11/25/05 15:30

ALARM
Fill Stuck Open
Started/Ended at:
11/25/05 15:30

ALARM
Fill Stuck Closed
Started/Ended at:
11/25/05 15:30

ALARM
Power Failure
Started/Ended at:
11/25/05 15:30

Communications
Loss Unit 2
Started/Ended at:
11/25/05 15:30

NEW SETTING ACCEPTED

Communications Loss
Check Controller

(English Only)

INVALID SETTING
Please try again

Updating
Please wait

Controller Busy
Please try again

Calibration aborted!

Higher User Level
Required use ↑↓ to
ENTER Password
0000

Incorrect Password

ENTER Password
0000



10.0 PREVENTATIVE MAINTENANCE & TROUBLESHOOTING

10.1 Preventative Maintenance Schedule

MVE Variō System freezers are designed specifically for ease of use with minimal required maintenance, but as with any mechatronic device, preventative maintenance is the key to ensuring optimum operation and performance, as well as maximum service life.

NOTE: This is the *minimum* MVE endorsed preventative maintenance schedule. MVE Distributors may have a more rigorous/comprehensive plan which may be substituted for the below according to the needs of the application.

MVE Variō Series Preventative Maintenance Schedule						
	Weekly	Monthly	6 Months	1 Year	2 Years	5 Years
Verify Adequate Supply	X					
Plumbing Leak Check		X				
High Temp Alarm Test			X			
Thaw Freezer Lid			X			
Folding Step Inspection			X			
Lid Hinge Inspection			X			
Inline Filter Replacement				X		
Complete Function Test				X		
Solenoid Valve Replacement					X	
Relief Valve Replacement					X	
Lid gasket replacement					X	
Complete Freezer Thaw and Moisture Removal						X



10.2 Preventative Maintenance Procedures

10.2.1 Calibrating the Pt1000 Temperature Sensors

10.2.1.1 Single Point

The single point calibration procedure requires a small volume of liquid nitrogen – enough to completely submerge the end of the temperature sensor.

- | | |
|---|---|
| 1. From the home screen, press <i>SETUP</i> to enter setup menus. If Password Entry Mode is enabled, the controller will prompt for a password. Use the ▲/▼ keys to scroll to the appropriate number and press <i>ENTER</i> to advance the cursor to the next position. | Higher User Level Required use ▲▼ to ENTER Password 0000 |
| 2. After entering password, the first menu item is <i>Temperature Menus</i> . Press <i>ENTER</i> . | Press ENTER for Temperature menus or press SETUP for next menu |
| 3. Press <i>SETUP</i> repeatedly to scroll to the menu item corresponding to the sensor being calibrated and press <i>ENTER</i> . | Press ENTER for Temp A/B menu or press SETUP for next menu |
| 4. Press <i>SETUP</i> repeatedly to scroll to the calibration menu and press <i>ENTER</i> . | Press ENTER for Temp A/B Calibration or press SETUP for next menu |
| 5. At the <i>Calibration Type</i> display, press <i>ENTER</i> to select the single point calibration method. | Calibration Type SINGLE POINT Use ▲▼ to adjust Press ENTER for next |
| 6. Submerge the temperature sensor in liquid nitrogen and press <i>ENTER</i> . | Temp A/B Calibration Place Probe A/B in LN2 and press ENTER |
| 7. Monitor the displayed temp sensor reading. When the reading has stabilized, press <i>ENTER</i> . | Wait for Temp A/B to stabilize then press ENTER Temp A -196.2 °C |
| 8. The <i>Calibration Complete</i> screen will be display. Press <i>ESC</i> repeatedly to return to the home screen. | Probe A/B single point calibration complete |



10.2.1.2 Dual Point

The dual point calibration procedure requires a small volume of liquid nitrogen and ice water – enough to completely submerge the end of the temperature sensor. To ensure accuracy, proper ice water bath preparation is imperative. For the best results, add filtered water to a Styrofoam cup containing crushed ice. Allow the solution to stand at room temperature for five minutes prior to beginning procedure.

- | | |
|---|--|
| 1. From the home screen, press <i>SETUP</i> to enter setup menus. If Password Entry Mode is enabled, the controller will prompt for a password. Use the ▲/▼ keys to scroll to the appropriate number and press <i>ENTER</i> to advance the cursor to the next position. | Higher User Level
Required use ▲▼ to
ENTER Password
0000 |
| 2. After entering password, the first menu item is <i>Temperature Menus</i> . Press <i>ENTER</i> . | Press ENTER for
Temperature menus
or press SETUP for
next menu |
| 3. Press <i>SETUP</i> repeatedly to scroll to the menu item corresponding to the sensor being calibrated and press <i>ENTER</i> . | Press ENTER for
Temp A/B menu
or press SETUP for
next menu |
| 4. Press <i>SETUP</i> repeatedly to scroll to the calibration menu and press <i>ENTER</i> . | Press ENTER for
Temp A/B Calibration
or press SETUP for
next menu |
| 5. At the <i>Calibration Type</i> display, use the ▲/▼ keys to select the two point calibration method and press <i>ENTER</i> . | Calibration Type
TWO POINT
Use ▲▼ to adjust
Press ENTER for next |
| 6. Submerge the temperature sensor in liquid nitrogen and press <i>ENTER</i> . | Temp A/B Calibration
Place Probe A/B in
LN2 and press
ENTER |
| 7. Monitor the displayed temp sensor reading. When the reading has stabilized, press <i>ENTER</i> . | Wait for Temp A/B to
stabilize then press
ENTER
Temp A -196.2 °C |
| 8. Remove the sensor from LN2 and press <i>ENTER</i> . | Remove Probe A/B from
LN2 and press
ENTER |
| 9. Allow the sensor to warm as the timer expires. | Wait while probe
warms to room
temperature
180 seconds |
| 10. Submerge the temperature sensor in the ice water bath. | Place Probe A in
ice water and press
ENTER |

11. Wait for the sensor reading to stabilize and press *ENTER*.

Wait for Temp A/B to stabilize then press ENTER
Temp A/B 0.0 °C

12. The *Calibration Complete* screen will be display. Press *ESC* repeatedly to return to the home screen.

Probe A/B two point calibration complete

10.2.2 Testing the Remote Alarm Contacts

10.2.2.1 Global Alarm Contacts

The MVE Variō Pro is equipped with a global alarm relay that allows for the remote monitoring of all alarm conditions. Once activated, these latching contacts will retain their alarm state until the alarm condition is corrected and cleared. Although Chart MVE does not provide remote alarm monitoring systems, such devices may be easily connected to the MVE Variō Pro. Wires can be inserted and removed from the global remote terminals by placing a small flathead screwdriver into the slot above the contact and prying down the latch until the clamp connector opens. Remove the flathead screwdriver to close the clamp connector.

The Global Remote contacts may be checked for continuity using a digital multimeter or ohm meter. Under normal operating conditions with no alarms, there should be continuity between the common (COM) and normally closed (NC) contacts. The COM – normally open (NO) circuit should be open. Under alarm conditions, the state of each relay will be reversed, closing the COM-NO circuit and opening the COM-NC circuit.

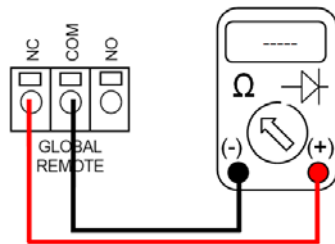

10.2.2.2 Discrete Alarm Contacts

The MVE Variō Pro DB15 connection allows for the remote monitoring of the high and low Temp A alarms, the stuck valve alarms, the open lid alarm, and the sensor failure alarms. These normally open, latching alarms will remain in state of alarm until the alarm condition is removed and cleared.

To test these alarms, produce the desired alarm condition and verify continuity between the common pin (PIN 15) and the pin corresponding to the triggered alarm, as shown below.

Alarm PIN Assignments	
Alarm	PIN
High/Low Temp A Alarm	6
Lid Open Alarm	7
Sensor Failure Alarm	8
Stuck Valve Alarm	13
Common	15



10.2.3 Plumbing Leak Check

Leaky plumbing connections can create a host of problems including excessive cooling cycle times, nuisance alarms, and high nitrogen consumption. Leaky plumbing connections are especially common on liquid cylinder supply systems due to the frequent attachment/removal of fittings when changing cylinders.

To check the plumbing for leaks:

1. With the supply system at operating pressure, thoroughly spray all transfer hose connections and freezer plumbing connections with a leak detecting solution.
2. Allow solution to penetrate fittings for a minimum of 30 seconds. Large leaks will be immediately apparent with large bubble formations. Smaller leaks will take longer to detect, and cause the solution to adopt a foam-like appearance.
3. Tighten fittings as necessary.
4. If tightening the fitting does not fix the leak, check the fitting for cracks and or galling and replace as necessary.
5. Upon replacement, recheck the plumbing to ensure proper installation.

10.2.4 Variō Pro Firmware Update

As with any electronic device, the Variō Pro firmware, or the software that defines controller operation, may be modified from time to time in order to provide better performance, additional features, or patch known issues. Accordingly, it is imperative that the firmware on the device be updated with the release of each firmware revision. For information on how to perform a firmware update, or verify the current firmware revision, contact an authorized MVE Distributor or Chart Technical Service.



NOTE: The Variō Pro firmware should only be updated by an authorized MVE Distributor or under the direction of Chart Technical Service. Improperly performed firmware updates may render the controller inoperable.

10.2.5 Verifying Adequate LN2 Supply

Adequate LN2 supply pressure and flow is imperative to the proper operation of MVE Variō Series freezers. Any LN2 supply, whether from bulk tank or liquid cylinder, must be able to maintain a pressure of 22-35 psi (1.52 – 2.41 bar) during a cooling cycle, and must have enough liquid to ensure the completion of a cooling cycle. The majority of nuisance alarms reported from MVE freezers are due to inadequate supply conditions.

Observe the pressure of the supply source. Ideally, pressure should be 22 – 35 psi (1.52 – 2.41 bar). It is common for the pressure gauge on an industrial liquid cylinder to be inoperative. If you suspect this to be the case, install a pressure gauge inline between the liquid cylinder and the freezer for pressure verification. Initiate a cooling cycle on at least one freezer on the network. The supply system should be able to maintain appropriate pressure throughout the duration of the cooling cycle.

Verify the amount of liquid in the supply source. Most bulk tanks have some method of digital or analog volume measurement. Liquid cylinders typically use a sight gauge. As with the pressure gauge on liquid cylinders, it is common for the sight gauge to be inoperative.

If the supply is determined to be inadequate, have your gas supplier replenish or replace the system.



10.2.6 High Temperature Alarm Test

The high temperature alarm test allows a user to simulate a high temperature alarm without having to remove the corresponding sensor from the freezer. Once initiated, the Variō Pro will warm the sensor by applying a small voltage to the sensor leads. The Variō Pro will continue to heat the sensor until it exceeds the High Temp Alarm setpoint, at which time it will remove the applied voltage and terminate the testing procedure.



NOTE: The heat generated by the sensor during the high temperature alarm test is NOT enough to affect the actual temperature in the freezer storage space.

1. From the home screen, press *SETUP* to enter setup menus. If Password Entry Mode is enabled, the controller will prompt for a password. Use the ▲/▼ keys to scroll to the appropriate number and press *ENTER* to advance the cursor to the next position.
2. After entering password, the first menu item is *Temperature Menus*. Press *ENTER*.
3. The first menu item is *Temp A Menu*. For Temp B, press *SETUP* to scroll to *Temp B Menu*. Press *ENTER*.
4. Press *SETUP* to scroll to the *Alarm Test* display and use the ▲/▼ keys to change the selection to *YES*. Press *ENTER* to initiate testing procedure.
5. The sensor readings will begin to climb and surpass the alarm setpoint, triggering the high temperature alarm. Once the alarm has been triggered, the test will be terminated and the sensor reading will return to normal.

Higher User Level
Required use ▲▼ to
ENTER Password
0000

Press ENTER for
Temperature menus
or press SETUP for
next menu

Press ENTER for
Temp A/B menu
or press SETUP for
next menu

Initiate High Temp A/B
Alarm Test
YES
Temp A/B -85.2°C

Initiate High Temp A/B
Alarm Test
TESTING
Temp A/B -68.7°C

Note: For testing integrity, the testing circuit is independent of the monitoring circuit (i.e. the controller does not "see" the test). If the sensor being tested is the current driving sensor, a cooling cycle will be initiated and will persist until the minimum chamber temperature setpoint has been reached.

10.2.7 Lid Thaw Procedure

1. Remove the lid from the freezer. Depending on the freezer model, it may be necessary to remove the lid from the hinges for it to completely warm to room temperature.
2. It is recommended that the freezer opening be covered with a spare lid or in another non-airtight manner to prevent moisture from entering the storage space.
3. Allow lid to sit at room temperature until thawed.
4. Once thawed, thoroughly dry lid, cork, and liner.
5. Inspect lid for damage and replace if necessary.

10.2.8 Folding Step Inspection

When inspecting the step assembly, verify that the hinges are free of cracks and that all connections are secure. Verify the integrity of the anti-slip strips and replace if necessary (PN 4810179). Ensure the step locking strap is able to securely hold the steps in an upright, folded position. To prevent the pivot bolts from continuously loosening, apply thread locker (PN 11087674) to the bolt shaft and retighten.

10.2.9 Filter Replacement



CAUTION: Ensure that the LN2 supply valve is closed and the plumbing assembly is fully vented before attempting to remove the inline filter.

To remove and replace the inline filter:

1. Close the LN2 supply valve and disconnect the LN2 transfer hose from the plumbing assembly fill tee.
2. Loosen and remove the fill tee and inline filter from the plumbing assembly.
3. Replace the inline filter (PN 11648945) and reinstall the fill tee using new Teflon tape to wrap the threads. Ensure the filter is oriented correctly such that the imprinted arrow points in the direction of LN2 flow.
4. Reconnect the transfer hose, open the LN2 supply valve, and check fittings for leaks according to Section 10.2.3 on page 60.

10.2.10 Relief Valve Replacement



CAUTION: Ensure that the LN2 supply valve is closed and the plumbing assembly is fully vented before attempting to remove the relief valve.

1. Remove plumbing shroud to gain access to plumbing system.
2. If the valve is equipped with a deflector, loosen the clamp and remove the deflector.
3. Loosen the relief valve and remove it from the plumbing assembly. Support the attachment tube with a wrench to prevent damage from torsion.
4. Install a replacement relief valve rated to 50 PSI (3.4 bar) (PN 1810032) using new Teflon tape to wrap the threads.



WARNING: In addition to voiding any warranty, installing a relief valve with a pressure rating other than 50 PSI (3.4 bar) may prevent proper operation and lead to a dangerous over-pressurized condition.

10.2.11 Complete MVE Variō Pro Function Test

MVE recommends that freezers with MVE Variō Pro controllers undergo a complete function test every 12 months to ensure correct functionality and identify potential problems before symptoms develop. Function test documents may be written based on this manual, or the manual itself may be used to verify proper functionality.

10.2.12 Solenoid Valve Replacement

All MVE freezers equipped with electromechanical solenoid valves have been tested and approved by MVE for cryogenic use. These valves utilize a PTFE seal for optimal sealing in cryogenic environments. Over time, the normal thermal cycling that this seal endures will cause it to harden and eventually lose its ability to seal sufficiently, possibly resulting in increased LN2 consumption, and in extreme cases, an overflow situation.

Thermal cycling may also cause moisture ingress into the coil of the solenoid valve. Over time, this may cause the connections and wiring in the coil to corrode and eventually fail.

Although thermal cycling will occur with normal operation, its effects are easily avoided with light preventative maintenance. To remove and replace a faulty valve, follow the steps below.

 **WARNING:** Only MVE supplied valves may be used on the MVE Variō System. In addition to voiding any warranty, substituting non-MVE components may result in inoperable valves and even damage to the MVE Variō Pro control system.

 **CAUTION:** Ensure that the LN2 supply valve is closed and the plumbing assembly is fully vented before attempting to remove the valve.

1. Remove plumbing shroud to gain access to plumbing system.
2. Disconnect the solenoid valve from the controller.
3. Remove coil retaining clip by inserting a flathead screwdriver between the clip and the edge of the coil body. Twist the screwdriver and allow the clip to slide off.
4. Remove and discard the coil assembly.
5. Using a crescent wrench, loosen the hex nut and remove the plunger housing and plunger assembly.
6. Remove any debris that may have collected in brass valve body.
7. Inspect the brass valve body for nicks or other damage. If the sealing surface appears to be in good condition, the valve body may be reused. Although uncommon, if the sealing surface is damaged, the plumbing will need to be disassembled and the entire valve body will need to be replaced. When installing a new valve body, verify correct orientation by ensuring the imprinted arrow points in the direction of LN2 flow.
8. Disassemble a new MVE supplied valve (PN 14224611S) using the above procedure.
9. Install the new plunger, plunger housing, and coil assembly onto the old valve body.
10. Assembly valve with new components in the reverse order.
11. Reconnect the valve to the Variō Pro controller.
12. Verify that no leaks are present using leak detect solution.
13. Open the LN2 supply valve and manually initiate a cooling cycle. Allow the cooling cycle to complete and verify that flow stops at the termination of the cycle.

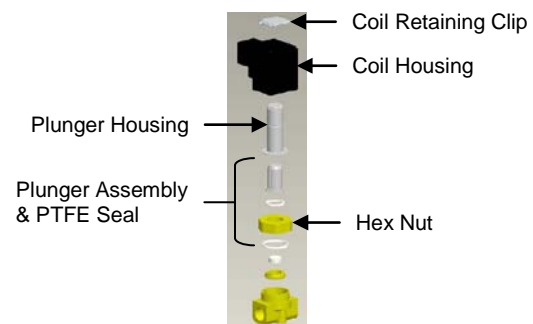
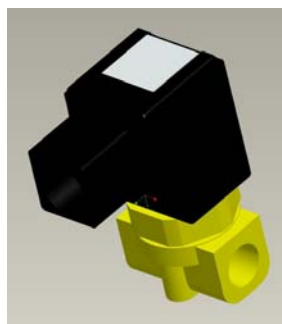

10.2.13 Lid Gasket Replacement

10.2.13.1 MVE Variō 1500 Series

Depending on the condition of the current gasket, the gasket material may either be removed or more material may be added to the existing gasket. The replacement gasket material will be a neoprene tape.

1. Clean the attachment surface.
2. Remove the tape backing on the gasket material to expose adhesive strip.
3. Trim to size as needed and install onto lid.
4. Cut a 4 inch gap in the gasket material on either side of the lid as shown below to allow sufficient venting of the freezer space.

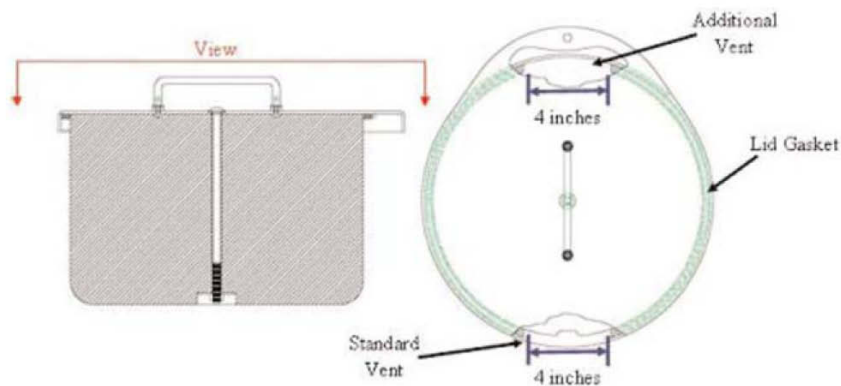

10.2.13.2 MVE Variō 1800 Series

The MVE Variō 1800 Series lid has a trim seal gasket that slides securely around the circumference of the lid without additional adhesive or rivets.

1. Remove the existing gasket by simply pulling off the trim seal gasket.
2. Install new gasket starting at the rear center of the lid. Insert trim seal around lid edge so that the trim lip secures to the lid. Install around the entire lid.
3. Cut a 8 inch gap in the gasket material at the rear center under the lid hinge to allow sufficient venting of the freezer space.

10.2.14 Complete Freezer Thaw & Moisture Removal

1. Close LN2 supply valve and remove LN2 supply.
2. Remove all power sources from the Variō Pro controller.
3. Open or remove lid from freezer.
4. Allow the freezer storage space to warm to room temperature. A fan or similar device may be used to accelerate the warming process.
5. After the freezer has reached ambient temperature, thoroughly purge any moisture from the freezer space. This can be done with a wet/dry vacuum and towels. Open the hinged hatch on the bottom of the turn-tray to access the bottom of the freezer.
6. Once moisture has been removed from the freezer, purge the plumbing assembly with gaseous nitrogen at a pressure no greater than 50 PSI (3.4 bar) for 30 seconds. Repeat 30 second purging cycles until the plumbing assembly is completely dry.



10.3 Accessories & Replacement Parts

MVE Variō System Accessories	
Item Description	Part Number
COM Kit: RJ-45 to USB Convertor	13376947
Network Setup Kit: 1 RJ-45 network cable & 1 cable splitter	10856321
RJ-45 Network Cable	10740053
RJ-45 Cable Splitter	10856312
Supply T-Assembly: used to connect 2 freezers to one LN2 supply connection	10784443
Relief Valve Inline Adapter: 3/8" NPT	1611592
Relief Valve Inline Adapter: 1/2" inch NPT Outlet	1810092
Cool Reach: cryo-compatible squeeze-grip used to retrieve hard to reach items	13051579
LN2 Transfer Hose: 4 ft (1220 mm), ½ inch (12.7 mm) ODT	9713159
6 ft (1829 mm), ½ inch (12.7 mm) ODT	9713109
LN2 Transfer Hose Coupler: used to connect two transfer hoses.	1110862
Printer Kit: includes printer and cables	11544943
Cryo Gloves: Medium; Length: Mid-arm	9717119
Large; Length: Mid-arm	9717129
X-Large; Length: Mid-arm	9717139
Medium; Length: Elbow	9717149
Large; Length: Elbow	13376947
X-Large; Length: Elbow	10856321
Cryo Apron	10740053
Automatic LN2 Supply Switcher	10856312

Replacement Parts	
Item Description	Part Number
Inline Filter: 40 micron mesh	11648945
Relief Valve: 50 PSI (3.4 bar)	1810032
SMC Solenoid Valve: cooling & bypass valves	14224611S
Inlet Temperature Sensor	10713400
Gas Bypass Muffler	11499812
Gas Bypass Muffler Deflector	11885449
Temperature Probe: 96 inch (2438 mm)	10713354
Temperature Probe: 44 inch (1118 mm)	10713418
3-Tube Temp Sensor Guide for 1500 Series: 39 inch (990 mm)	14248816
3-Tube Temp Sensor Guide for 1800 Series: 44 inch (1118 mm)	14248752
Jerome Power Supply: Input: 110-230 VAC; Output: 30 VDC	11795030
Power Outlet Cord: 110 VAC (The Americas)	14010103
Power Outlet Cord: 230 VAC (Europe)	10995363
Battery Backup Replacement Battery: 12 VDC	10718155
Battery Backup Fuse: 4A 250V	11858467

11.0 EN COMPLIANCE TABLES

Table 201: Guidance and manufacturer’s declaration – electromagnetic emissions for all MVE Variō Pros (see 6.8.3.201 a) 3).

Guidance and Manufacturer’s Declaration - Electromagnetic Emissions		
The MVE Variō Pro is intended for use in the electromagnetic environment specified below. The customer or the user of the MVE Variō Pro should assure that it is used in such an environment.		
Emissions Test	Compliance	Electromagnetic Environment – Guidance
RF emissions CISPR 11	Group 1	The MVE Variō Pro uses RF energy only for its internal functions. Therefore, its RF emissions are very low and are not likely to cause any interference in nearby electronic equipment.
RF emissions CISPR 11	Class B	The MVE Variō Pro is suitable for use in all establishments, including domestic establishments and those directly connected to the public low-voltage power supply network that supplies buildings used for domestic purposes.
Harmonic emissions IEC 61000-3-2	Class A	
Voltage fluctuations / Flicker emissions IEC 61000-3-3	Complies	

Table 202: Guidance and manufacturer’s declaration – electromagnetic immunity – for all MVE Variō Pros (see 6.8.3.201 a) 6).

Guidance and Manufacturer’s Declaration – Electromagnetic Immunity			
The MVE Variō Pro is intended for use in the electromagnetic environment specified below. The customer or the user of the MVE Variō Pro should assure that it is used in such an environment.			
Immunity Test	IEC 60601 Test Level	Compliance Level	Electromagnetic Environment – guidance
Electromagnetic Discharge (ESD) IEC 61000-4-2	±6 kV contact ±8 kV air	±6 kV contact ±8 kV air	Floors should be wood, concrete, or ceramic tile. If floors are covered with synthetic material, the relative humidity should be at least 30%
Electrical fast transient/burst IEC 61000-4-4	±2 kV for power supply lines ±1 kV for input/output lines	±2 kV for power supply lines ±1 kV for input/output lines	Mains power quality should be that of a typical commercial or hospital environment.
Electrical fast transient/burst IEC 61000-4-5	±2 kV for power supply lines ±1 kV for input/output lines	±2 kV for power supply lines ±1 kV for input/output lines	Mains power quality should be that of a typical commercial or hospital environment.
Surge IEC 61000-4-11	<5% U_T (>95% dip in U_T) For 0,5 cycle <40% U_T (>60% dip in U_T) For 5 cycles <70% U_T (>30% dip in U_T) For 25 cycles <5% U_T (>95% dip in U_T) For 5 seconds	<5% U_T (>95% dip in U_T) For 0,5 cycle <40% U_T (>60% dip in U_T) For 5 cycles <70% U_T (>30% dip in U_T) For 25 cycles <5% U_T (>95% dip in U_T) For 5 seconds	Mains power quality should be that of a typical commercial or hospital environment. If the user of the MVE Variō Pro requires continued operation during power mains interruptions, it is recommended that the MVE Variō Pro be powered by an uninterruptible power supply or battery.
Power frequency (50/60 Hz) Magnetic field IEC 61000-4-8	3 A/m	3 A/m	Power frequency magnetic fields should be at levels characteristic of a typical location in a typical commercial or hospital environment.
NOTE: U_T is the AC mains voltage prior to application of the test level			

Table 202: Guidance and manufacturer’s declaration – electromagnetic immunity – for all MVE Variō Pros (see 6.8.3.201 b).

Guidance and Manufacturer’s Declaration – Electromagnetic Immunity			
The MVE Variō Pro is intended for use in the electromagnetic environment specified below. The customer or the user of the MVE Variō Pro should assure that it is used in such an environment.			
Immunity Test	IEC 60601 Test Level	Compliance Level	Electromagnetic Environment – guidance
<p>Conducted RF IEC 61000-4-6</p> <p>Radiated RF IEC 61000-4-3</p>	<p>3 Vrms 150 kHz to 80 MHz</p> <p>3 V/m 80 MHz to 2,5 GHz</p>	<p>3 V</p> <p>3 V/m</p>	<p>Portable and mobile RF communications equipment should be used no closer to any part of the MVE Variō Pro including cables, than the recommended separation distance calculated from the equation applicable to the frequency of the transmitter. Recommended separation distance $d = [3,5/V1]\sqrt{P}$</p> <p>$d = [3,5/E1]\sqrt{P}$ 80 MHz to 800 MHz $d = [7/E1]\sqrt{P}$ 800 MHz to 2,5 GHz</p> <p>where P is the maximum output power rating of the transmitter in watts (W) according to the transmitter manufacturer and d is the recommended separation distance in meters (m).</p> <p>Field strengths from fixed RF transmitter as determined by an electromagnetic site survey^a, should be less than the compliance level in each frequency range^b.</p> <p>Interference may occur in the vicinity of equipment marked with the following symbol:</p> 
<p>NOTE 1: At 80 MHz and 800 MHz the higher frequency range applies</p> <p>NOTE 2: These guidelines may not apply in all situations. Electromagnetic propagation is affected by absorption and reflection from the structures, objects, and people.</p> <p>^a Field strengths from fixed transmitters such as base stations for radio (cellular/cordless) telephones and land mobile radios, amateur radio, AM, and FM radio broadcast and TV broadcast cannot be predicted theoretically with accuracy. To assess the electromagnetic environment due to fixed RF transmitters, an electromagnetic site survey should be considered. If the measured field strength in the location in which the MVE Variō Pro is used exceeds the applicable RF compliance level above, the MVE Variō Pro should be observed to verify normal operation. If abnormal performance is observed, additional measures may be necessary, such as reorienting or relocating the MVE Variō Pro.</p> <p>^b Over the frequency range 150 kHz to 80 MHz, field strengths should be less than $[V1]$ V/m.</p>			



Table 206: Recommended separation distances between portable and mobile RF communications equipment and the MVE Variō Pro – for MVE Variō Pro systems that are not life supporting (see 6.8.3.201 b).

Recommended separation distances between portable and mobile RF communications equipment and the MVE Variō Pro			
The MVE Variō Pro is intended for use in the electromagnetic environment in which radiated RF disturbances are controlled. The customer or the user of the MVE Variō Pro can help prevent electromagnetic interference by maintaining a minimum distance between portable and mobile RF communications equipment (transmitters) and the MVE Variō Pro as recommended below, according to the maximum output power of the communications equipment.			
Rated maximum output power of transmitter (W)	Separation distance according to frequency of transmitter (m)		
	150 kHz to 80 MHz $d = [3,5/\sqrt{1}] \sqrt{P}$	80 MHz to 800 MHz $d = [3,5/\sqrt{E1}] \sqrt{P}$	800 MHz to 2,5 GHz $d = [7/\sqrt{E1}] \sqrt{P}$
0,01	0,12	0,12	0,23
0,1	0,38	0,38	0,73
1	1,2	1,2	2,3
10	3,8	3,8	7,3
100	12	12	23
For transmitters rated at a maximum output power not listed above, the recommended separation distance d in meters (m) can be estimated using the equation applicable to the frequency of the transmitter where P is the maximum output power rating of the transmitter in watts (W) according to the transmitter manufacturer.			
NOTE 1: At 80 MHz and 800 MHz the higher frequency range applies			
NOTE 2: These guidelines may not apply in all situations. Electromagnetic propagation is affected by absorption and reflection from the structures, objects, and people.			



12.0 APPENDIX

12.1 ASCII Interface & Command Index

Control Commands:
<p>Controller ID Input: *IDN? Output: Chart MVE Variō Pro, Software ver. #.## Description: Returns the controller type & software revision.</p>
<p>Alarm Mute Input: ALMS 0 Output: None Description: Same effect as pressing <i>ALARM MUTE</i> button.</p>
<p>Alarms Active Input: ALMS? Output: # Output Range: 0, 1 Description: Displays “1” if an alarm is currently active and “0” if no alarms are currently active.</p>
<p>Calibrate Temp A Input: CALTA Output: None Description: Calibrates Temp A in LN2.</p>
<p>Calibrate Temp B Input: CALTB Output: None Description: Calibrates Temp B in LN2.</p>
<p>Global Password Input: CODE? Output: #### Output Range: 0000 – 9999 Description: Displays Global Password.</p>
<p>Test High Temp A Alarm Input: HITSTA Output: None Description: Initiates High Temp A Alarm Test.</p>
<p>Test High Temp B Alarm Input: HITSTB Output: None Description: Initiates High Temp B Alarm Test.</p>
<p>Restore Manufacturer Defaults Input: INITEE Output: None Description: Restores all default settings.</p>

**Control Commands:****Set LN2 Saturation Temperature**

Input: LNSATP ±###.#

Input Range: See “Saturation Temperature Page” (Page 78).

Output: None

Description: Sets the Liquid Nitrogen Saturation temperature.

Get LN2 Saturation Temperature

Input: LNSATP?

Output: ±###.#

Output Range: See “Saturation Temperature Page” (Page 78).

Description: Displays the Liquid Nitrogen Saturation temperature.

Set Password Entry Mode

Input: LOCK #

Input Range: 0,1

Output: None

Description: Setting to “0” disables Password Entry Mode. Setting to “1” enables Password Entry Mode.

Get Password Entry Mode

Input: LOCK?

Output: #

Output Range: 0,1

Description: Returns “0” if Password Entry Mode is disabled. Returns “1” if Password Entry Mode is enabled.

Temperature Commands:**Get Inlet Temp**

Input: BPTMP?

Output: ±###.#, or OPEN

Description: Displays current inlet temperature.

Get Inlet Temp Setpoint

Input: INSET?

Output: ±###.#

Description: Displays current Inlet Temperature set point.

Set Inlet Temp Setpoint

Input: INSET ±###.#

Input Range: See “Inlet Temp Setpoint Page” (Page 86).

Output: None

Description: Sets inlet temperature setpoint.

Get Chamber Deadband

Input: CHDB?

Output: ±###.#

Description: Displays current chamber deadband value.

Set Chamber Deadband

Input: CHDB ±###.#

Output: None

Description: Sets the chamber deadband value.

**Temperature Commands:**

Get Chamber Temp

Input: CHTMP?

Output: ±###.# or OPEN

Description: Displays current Chamber Temperature.

Get Max Chamber Temp

Input: CHSET?

Output: ±###.#

Description: Displays current Max Chamber Temperature setpoint.

Set Max Chamber Temp

Input: CHSET ±###.#

Output: None

Description: Sets Max Chamber Temperature.

Get Cooling Coil Deadband

Input: CODB?

Output: ±##.#

Description: Displays current Cooling Coil Deadband.

Set Cooling Coil Deadband

Input: CODB ##.#

Output: None

Description: Sets Cooling Coil Deadband.

COSET?

Input: COSET?

Output: ±###.#

Description: Displays current Minimum Cooling Temperature Setpoint.

COSET

Input: COSET ±###.#

Input Range: See “Min Coil Outlet Temp Page” (Page 115).

Output: None

Description: Sets current Minimum Cooling Temperature Setpoint.

COTMP?

Input: COTMP?

Output: ±###.# or OPEN

Description: Displays current Cooling Temperature.

HITA

Input: HIT A ±###.#

Output: None

Description: Sets Temp A High Alarm to entered value.

HITA?

Input: HIT A?

Output: ±###.#

Description: Displays current setting of Temp A High Alarm.

**Temperature Commands:****HITAS?**

Input: HITAS?

Output: 0 or 1

Description: Displays "1" If there is currently a Temp A High Alarm and "0" if Temp A High Alarm is inactive.

HITAM

Input: HITAM #

Input Range: 0,1

Output: None

Description: Disables the Temp A High Alarm if set to "0". Enables the Temp A High Alarm if set to "1".

HITAM?

Input: HITAM?

Output: 0 or 1

Description: Displays "1" If the Temp A High Alarm is enabled. Displays "0" If the Temp A High Alarm is disabled.

HITB

Input: HITB ±###.#

Output: None

Description: Sets Temp B High Alarm to entered value.

HITB?

Input: HITB

Output: ±###.#

Description: Displays current setting of Temp B High Alarm.

HITBM

Input: HITBM #

Input Range: 0,1

Output: None

Description: Disables Temp B High Alarm if set to "0". Enables the Temp B High Alarm if set to "1".

HITBM?

Input: HITBM?

Output: 0 or 1

Description: Displays "1" If the Temp B High Alarm is enabled. Displays "0" If the Temp B High Alarm is disabled.

HITBS?

Input: HITBS?

Output: 0 or 1

Description: Displays "1" If there is currently a Temp B High Alarm. Displays "0" If there is currently not a Temp B High Alarm.

LOTA

Input: LOTA ±###.#

Output: None

Description: Sets Temp A Low Alarm to entered value.

**Temperature Commands:****LOTA?**

Input: LOTA?

Output: ±###.#

Description: Displays current Temp A Low Alarm setting.

LOTAM

Input: LOTAM #

Input Range: 0,1

Output: None

Description: Disables the Temp A Low Alarm if set to "0". Enables the Temp A Low Alarm if set to "1".

LOTAM?

Input: LOTAM?

Output: 0 or 1

Description: Displays "1" If the Temp A Low Alarm is enabled. Displays "0" If the Temp A Low Alarm is disabled.

LOTAS?

Input: LOTAS?

Output: 0 or 1

Description: Displays "1" If there is currently a Temp A Low Alarm. Displays "0" If there is currently not a Temp A Low Alarm.

LOTB

Input: LOTB ±###.#

Input Range: See "Temp B Low Alarm Setpoint Page" (Page 59).

Output: None

Description: Sets Temp B Low Alarm to entered value.

LOTB?

Input: LOTB?

Output: ±###.#

Description: Displays current Temp B Low Alarm setting.

LOTBM

Input: LOTBM #

Input Range: 0,1

Output: None

Description: Disables the Temp B Low Alarm if set to "0". Enables the Temp B Low Alarm if set to "1".

LOTBM?

Input: LOTBM?

Output: 0 or 1

Description: Displays "1" If the Temp B Low Alarm is enabled. Displays "0" If the Temp B Low Alarm is disabled.

LOTBS?

Input: LOTBS?

Output: 0 or 1

Description: Displays "1" If there is currently a Temp B Low Alarm. Displays "0" If there is currently not a Temp B Low Alarm.

**Temperature Commands:****TEMPA?**

Input: TEMPA?

Output: ±###.# or OPEN

Description: Displays current Temp A value.

TEMPB?

Input: TEMPB?

Output: ±###.# or OPEN

Description: Displays current Temp B value.

TUNI

Input: TUNI X

Input Range: C, F, or K

Output: None

Description: Sets temperature units of measurement based on entered character; 'C' for degrees Celsius, 'F' for degrees Fahrenheit and 'K' for Kelvin.

TUNI?

Input: TUNI?

Output: X

Output Range: C, F, or K

Description: Shows current units of measurement for temperature; 'C' for degrees Celsius, 'F' for degrees Fahrenheit and 'K' for Kelvin.

Cooling Cycle Commands**BPFIL?**

Input: BPFIL?

Output: 0 or 1

Description: Displays "1" if currently Bypassing. Displays "0" if not Bypassing.

CFIL?

Input: CFIL?

Output: 0 or 1

Description: Displays "1" if cooling cycle is active. Displays "0" if not actively cooling.



Data Logging Commands:

CLEVLG

Input: CLEVLG

Output: None

Description: Clears the data log.

Variance: After using this command, the EVENT? query will return PF (Power Failure) until there is at least one event in the data log.

DATE

Input: DATE MM/DD/YY or DATE DD/MM/YY depending on Date Format setting.

Output: None

Description: Sets the current date.

DATE?

Input: DATE?

Output: MM/DD/YY or DD/MM/YY depending on Date Format setting.

Description: Displays the current date.

EVENT?

Input: EVENT?

Output:

Normal Record:

[ID],[DATE],[TIME],[TEMPA],[TEMPB],[LEVEL],[RATE],[ALARMS/EVENTS]

Parameter Change

[ID],[DATE],[TIME],[TEMPA],[TEMPB],[LEVEL],[RATE],[ALARMS/EVENTS]

#####,MM/DD/YY,##:##,±###.#,±###.#,±###.#,±###.#,XX*

#####,MM/DD/YY,##:## XX,±###.#,±###.#, ±###.#,±###.#,XX*

#####,DD/MM/YY,##:## ,±###.#,±###.#,±###.#,±###.#,XX*

#####,DD/MM/YY,##:## XX,±###.#,±###.#, ±###.#,±###.#, XX*

#####,MM/DD/YY,##:##,Parameter number ### changed from #### to ####

#####,MM/DD/YY,##:## XX,Parameter number ### changed from #### to ####

#####,DD/MM/YY,##:##,Parameter number ### changed from #### to ####

#####,DD/MM/YY,##:## XX,Parameter number ### changed from #### to ####

Description: Returns the last event.

*XX can be multiple one or two character Alarm/Event codes where each code is separated by a space. If none are displayed there are no current alarms or events.

EVNCT?

Input: EVNCT?

Output: #####

Description: Returns the number of events stored.



Data Logging Commands:

EVNLOG?
Input: EVNLOG? #
Input Range: 1 – 30000

Output:
#####,MM/DD/YY,##:##,±####.#,±####.#,±####.#,±####.#,XX*
or #####,MM/DD/YY,##:## XX,±####.#,±####.#, ±####.#,±####.#,XX*
or #####,DD/MM/YY,##:## ,±####.#,±####.#,±####.#,±####.#,XX*
or #####,DD/MM/YY,##:## XX,±####.#,±####.#, ±####.#,±####.#, XX*
or #####,MM/DD/YY,##:##,Parameter number ### changed from #### to ####
or #####,MM/DD/YY,##:## XX,Parameter number ### changed from #### to ####
or #####,DD/MM/YY,##:##,Parameter number ### changed from #### to ####
or #####,DD/MM/YY,##:## XX,Parameter number ### changed from #### to ####

Description: Returns the specified event.

LOGPER
Input: LOGPER ###
Input Range: 1 – 1440

Output: None
Description: Sets the Log period in minutes.

LOGPER?
Input: LOGPER?

Output: ##### #

Description: Returns the Modbus ID and Log period in minutes.

MEMO
Input: MEMO # XXXX....
Input Range: 1 – 5

Output: None
Description: Sets the specified memo, # can be 1-5, for each available memo. The memo section (XXXX...) can contain up to 50 alphanumeric characters.

MEMO?
Input: MEMO? #
Input Range: 1 – 5

Output: XXXX....
Description: Returns the specified memo.

TIME
Input: TIME HH:MM:SS, in 24 hour format (:SS designation optional)

Output: None
Description: Sets time to entered value, use 24 hour format.

TIME?
Input: TIME?
Output: HH:MM:SS or HH:MM:SS XX depending on Time Format.

Description: Displays the current time.



Data Logging Commands:

UNID
Input: UNID #####
Input Range: 0 – 200
Output: None
Description: Sets the Unit ID number.

UNID?
Input: UNID?
Output: #####
Description: Displays Unit ID number.

CDATE?
Input: CDATE?
Output: XXX ## ##### #:##:##
Description: Displays compile date and time.