

# MVE 816P-2T-190 High Efficiency Freezer

Designed to meet the needs of the fertility/IVF repository



The all new MVE 816P-2T-190 freezer has been created with the fertility market in mind. This freezer is specifically designed to hold vials, straws and SUC-1 canisters which are used by leading fertility clinics worldwide. A constant temperature allows for vapor storage throughout the freezer at near liquid nitrogen temperatures. The innovative inventory system incorporates a two level storage arrangement that utilizes an access portal to allow removal of product stored on the lower level.

## Features/Benefits:

- Vapor phase storage temperature of  $-190^{\circ}\text{C}^*$
- Two tier storage system maximizes capacity while minimizing floor space
- High efficiency design with offset neck for lowest possible LN<sub>2</sub> consumption
- Available with Battery Backup and Hot Gas Bypass options
- TEC 3000 control system with liquid level control and temperature alarms
- Optional Step

\*Temperature tolerance of  $\pm 5^{\circ}\text{C}$

## Innovative Inventory System

Two tier storage (with cutout in top tier) allows convenient access to bottom tier.



## Temperature Test Graph

\* Temp Test indicates typical performance of 816P-2T -190°C freezer with full inventory system and factory recommended level settings. Actual performance may vary with atmospheric conditions and usage.

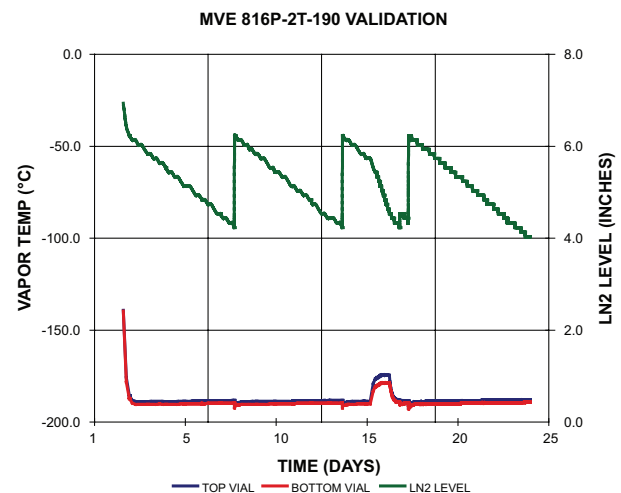

Visit [www.chartbiomed.com](http://www.chartbiomed.com) for more information.

Chart Inc. reserves the right to discontinue its products, or change the prices, materials, equipment, quality, descriptions, specifications and/or processes to its products at any time without prior notice and with no further obligation or consequence. All rights not expressly stated herein are reserved by us, as applicable.

## Rack Layout for SUC Boxes

115 SUC Boxes Total

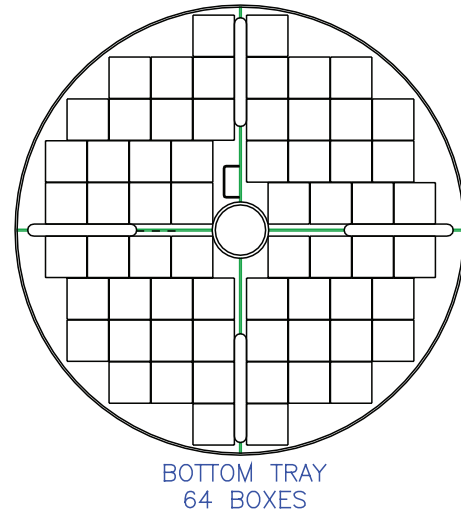
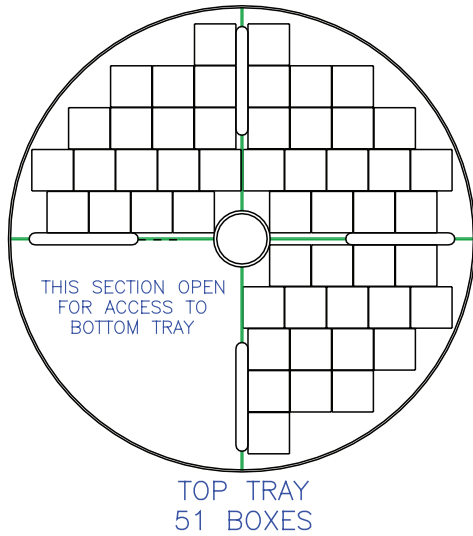

### Unit Dimensions

Neck Opening <i>in (mm)</i>	12.5 (317)
Usable Internal Height (per level) <i>in (mm)</i>	13 (330)
Inside Diameter (top) <i>in (mm)</i>	28.7 (728)
Inside Diameter (bottom) <i>in (mm)</i>	27.7 (702)
Outside Diameter <i>in (mm)**</i>	32 (813)
External Height <i>in (mm)</i>	50 (1271)
Liftover Height <i>in (mm)*</i>	40.3 (1024)
Weight Empty <i>lb. (kg)</i>	475 (215)
Weight Liquid Full <i>lb. (kg)</i>	1155 (524)

### Unit Capacities

SUC-1 Boxes	115
1.0 mL Vials	15870
1.2 mL Vials	16560
2.0 mL Vials	9200
0.5 cc Straws	35650
0.25 cc Straws	49910
LN2 Capacity (vapor operation)	56 liters

\*With optional step. Without optional step, liftover height is 48.3" (1227mm).

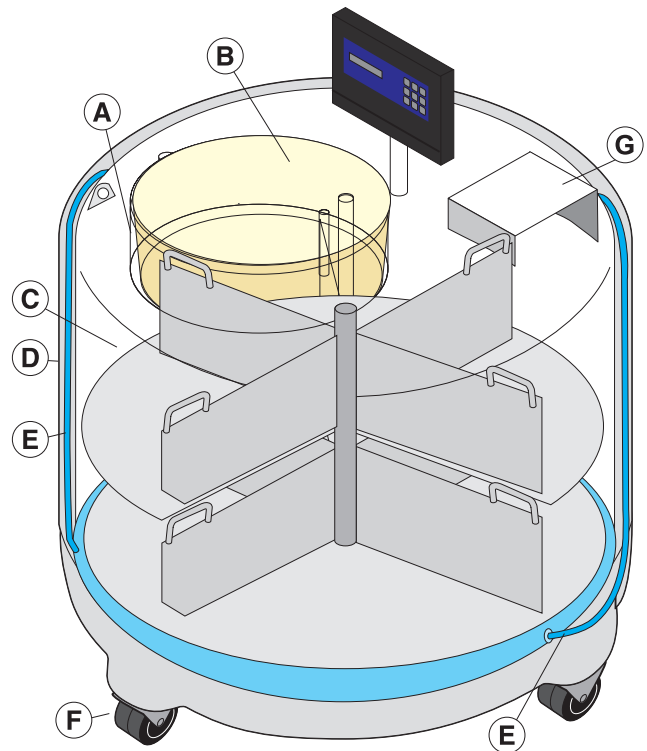

- A Offset neck design minimizes liquid nitrogen consumption
- B Lightweight composite lid is scratch and dent resistant
- C Two level rotating tray provides easy access to samples
- D Stainless steel construction reduces maintenance
- E Annular (internal) filling lines minimizes frost build up and reduces maintenance requirements
- F Durable casters equipped with brakes
- G Lid Stand

TWO Year Standard Warranty • FIVE Year Vacuum Warranty

Conforms to MDD 93/42/EEC, the Medical Device Directive for the EU. Freezer systems UL/C-UL Listed.

\* Without inventory

\*\* Minimum width required for vessel to pass through opening. Footprint may vary. Contact Tech Service for detailed drawings.